



YOUSHANG SEMICONDUCTOR

设计研发新型功率器件

各类小信号开关

中低压及高压大电流等场效应管

0755-83047638

ysbdt@szyoushang.cn

www.szyoushang.cn



企业微信二维码



企业QQ二维码

Description

This Bipolar Junction Transistor (BJT) is designed to meet the stringent requirements of automotive applications.

Features

- $BV_{CEO} > -40V$
- $I_C = -3A$ High Continuous Collector Current
- $I_{CM} = -5A$ Peak Pulse Current
- 2W Power Dissipation
- Low Saturation Voltage $V_{CE(SAT)} < -200mV @ -1.0A$

Applications

- DC to DC Conversion
- Supply Line Switching
- Low Dropout Regulation
- LCD Backlighting

Mechanical Data

- Case: SOT223
- Case Material: Molded Plastic, "Green" Molding Compound. UL Flammability Rating 94V-0
- Moisture Sensitivity: Level 1 per J-STD-020
- Terminals: Finish – Matte Tin Plated Leads. Solderable per MIL-STD-202, Method 208 [Ⓔ]
- Weight: 0.112 grams (Approximate)

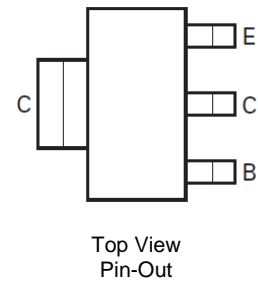
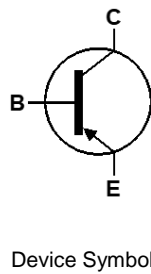
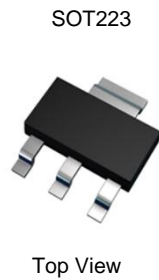

Absolute Maximum Ratings (@T_A = +25°C, unless otherwise specified.)

Characteristic	Symbol	Value	Unit
Collector-Base Voltage	V _{CB0}	-40	V
Collector-Emitter Voltage	V _{CEO}	-40	V
Emitter-Base Voltage	V _{EBO}	-6	V
Continuous Collector Current	I _C	-3	A
Peak Pulse Collector Current	I _{CM}	-5	A

Thermal Characteristics (@T_A = +25°C, unless otherwise specified.)

Characteristic	Symbol	Value	Unit
Power Dissipation (Note 6)	P _D	1.2	W
Thermal Resistance, Junction to Ambient (Note 6)	R _{θJA}	104	°C/W
Power Dissipation (Note 7)	P _D	2	W
Thermal Resistance, Junction to Ambient (Note 7)	R _{θJA}	62.5	°C/W
Operating and Storage Temperature Range	T _J , T _{STG}	-55 to +150	°C

ESD Ratings (Note 8)

Characteristic	Symbol	Value	Unit	JEDEC Class
Electrostatic Discharge – Human Body Model	ESD HBM	4,000	V	3A
Electrostatic Discharge – Machine Model	ESD MM	400	V	C

- Notes:
6. Device mounted on FR-4 PCB with minimum recommended pad layout.
 7. Device mounted on FR-4 PCB using 2oz copper and 25mm x 25mm pad layout.
 8. Refer to JEDEC specification JESD22-A114 and JESD22-A115.

Thermal Characteristics and Derating Information

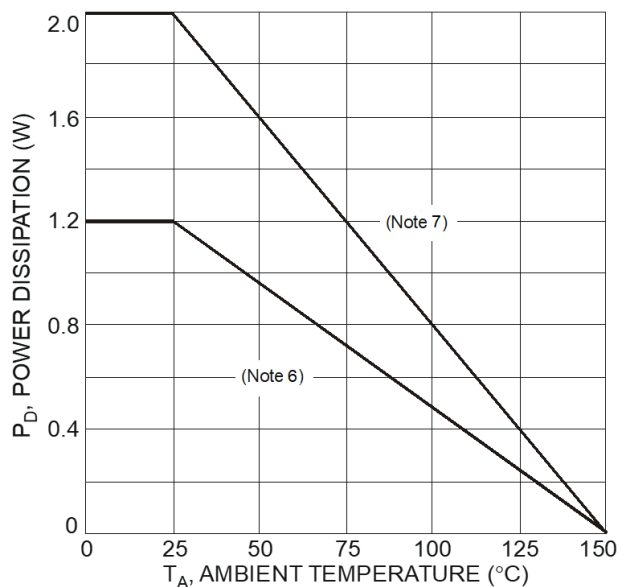

Fig. 1 Power Dissipation vs. Ambient Temperature

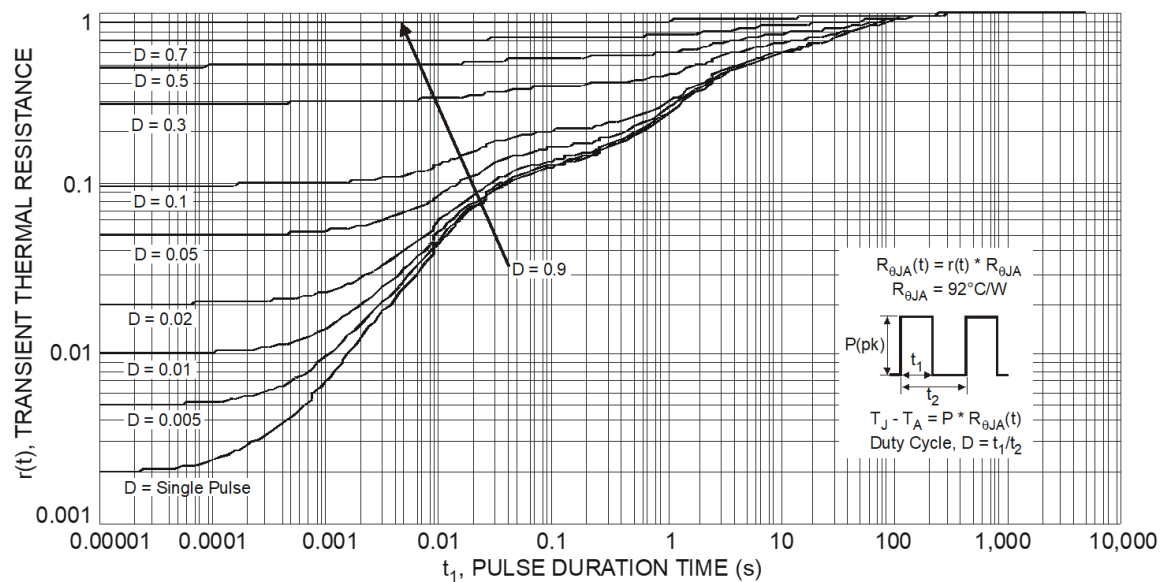

Fig. 2 Transient Thermal Response (Note 6)

Electrical Characteristics (@T_A = +25°C, unless otherwise specified.)

Characteristic	Symbol	Min	Typ	Max	Unit	Test Conditions
OFF CHARACTERISTICS (Note 9)						
Collector-Base Breakdown Voltage	BV _{CB0}	-40	—	—	V	I _C = -100μA
Collector-Emitter Breakdown Voltage	BV _{CEO}	-40	—	—	V	I _C = -10mA
Emitter-Base Breakdown Voltage	BV _{EBO}	-6	—	—	V	I _E = -50μA
Collector-Base Cutoff Current	I _{CB0}	—	—	-100	nA	V _{CB} = -40V, I _E = 0
		—	—	-50	μA	V _{CB} = -40V, I _E = 0, T _A = +150°C
Emitter-Base Cutoff Current	I _{EBO}	—	—	-100	nA	V _{EB} = -6V, I _C = 0
ON CHARACTERISTICS (Note 9)						
DC Current Gain	h _{FE}	220	—	—	—	V _{CE} = -1V, I _C = -0.5A
		200	—	400		V _{CE} = -1V, I _C = -1A
		100	—	—		V _{CE} = -1V, I _C = -3A
Collector-Emitter Saturation Voltage	V _{CE(SAT)}	—	—	-150	mV	I _C = -0.5A, I _B = -5mA
		—	—	-200		I _C = -1A, I _B = -10mA
		—	—	-500		I _C = -3A, I _B = -0.3A
Base-Emitter Saturation Voltage	V _{BE(SAT)}	—	—	-1.0	V	I _C = -1A, I _B = -0.1A
Base-Emitter Turn-On Voltage	V _{BE(ON)}	—	—	-1.0	V	V _{CE} = -2V, I _C = -1A
SMALL SIGNAL CHARACTERISTICS						
Transition Frequency	f _T	—	150	—	MHz	V _{CE} = -10V, I _C = -100mA, f = 100MHz
Output Capacitance	C _{obo}	—	35	—	pF	V _{CB} = -10V, f = 1MHz
Input Capacitance	C _{ibo}	—	150	—	pF	V _{CB} = -5V, f = 1MHz
SWITCHING CHARACTERISTICS						
Turn-On Time	t _{ON}	—	53	—	ns	V _{CC} = -10V, I _C = -2A, I _{B1} = -200mA
Delay Time	t _D	—	12	—	ns	
Rise Time	t _R	—	41	—	ns	
Turn-Off Time	t _{OFF}	—	180	—	ns	V _{CC} = -10V, I _C = -2A, I _{B1} = -I _{B2} = -200mA
Storage Time	t _S	—	146	—	ns	
Fall Time	t _F	—	34	—	ns	

Note: 9. Measured under pulsed conditions. Pulse width ≤ 300μs. Duty cycle ≤ 2%.

Typical Electrical Characteristics (@ $T_A = +25^\circ\text{C}$, unless otherwise specified.)

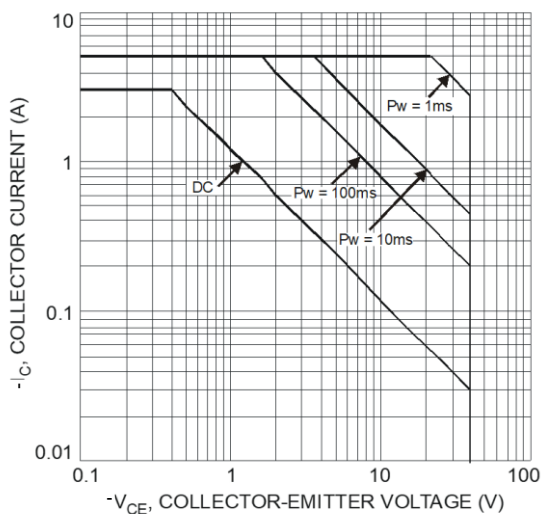

Fig. 3 Typical Collector Current vs. Collector-Emitter Voltage (Note 6)

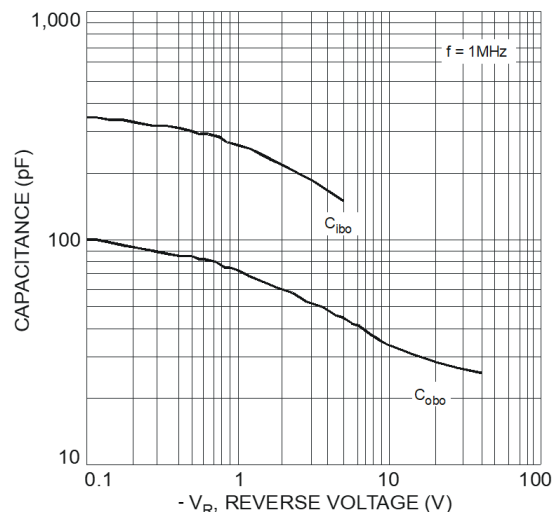

Fig. 4 Typical Capacitance Characteristics

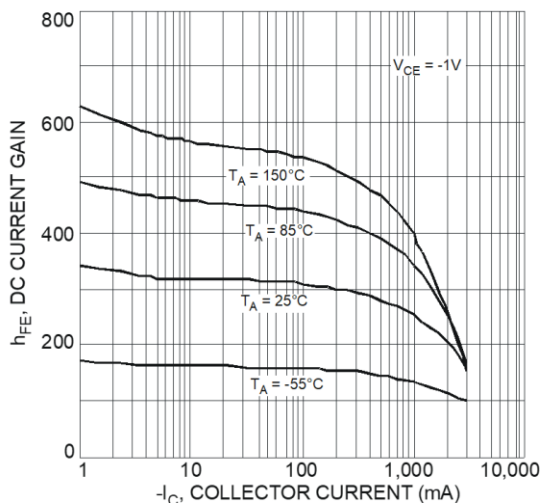

Fig. 5 Typical DC Current Gain vs. Collector Current

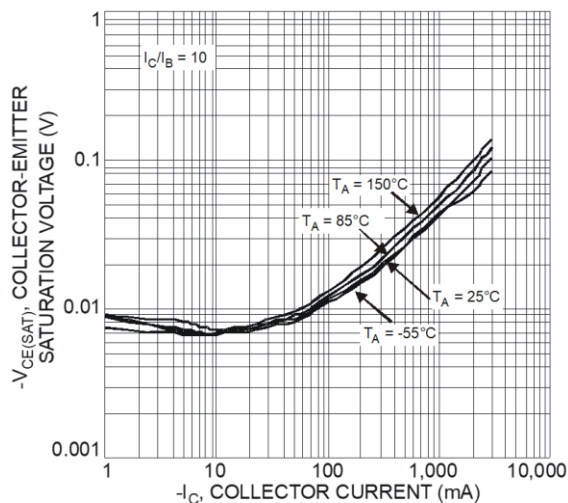

Fig. 6 Typical Collector-Emitter Saturation Voltage vs. Collector Current

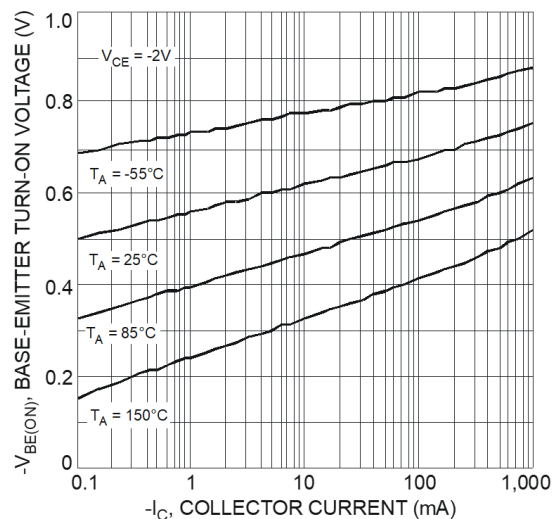

Fig. 7 Typical Base-Emitter Turn-On Voltage vs. Collector Current

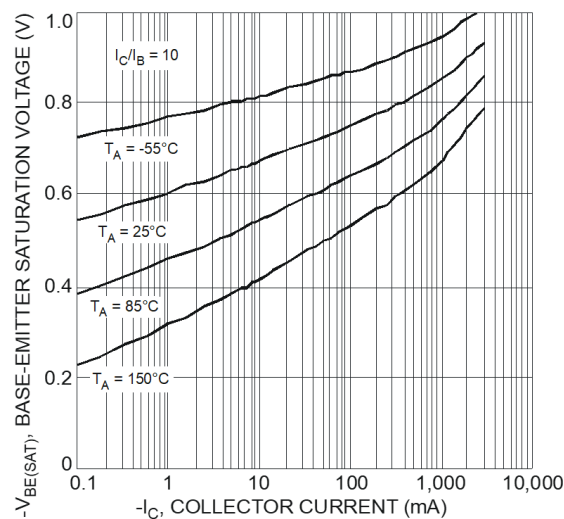
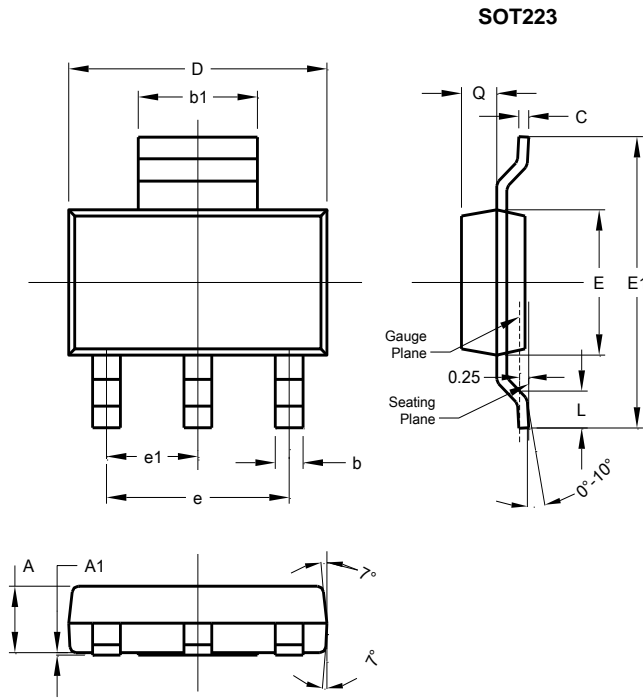

Fig. 8 Typical Base-Emitter Saturation Voltage vs. Collector Current

Package Outline Dimensions



SOT223			
Dim	Min	Max	Typ
A	1.55	1.65	1.60
A1	0.010	0.15	0.05
b	0.60	0.80	0.70
b1	2.90	3.10	3.00
C	0.20	0.30	0.25
D	6.45	6.55	6.50
E	3.45	3.55	3.50
E1	6.90	7.10	7.00
e	-	-	4.60
e1	-	-	2.30
L	0.85	1.05	0.95
Q	0.84	0.94	0.89
All Dimensions in mm			

Suggested Pad Layout

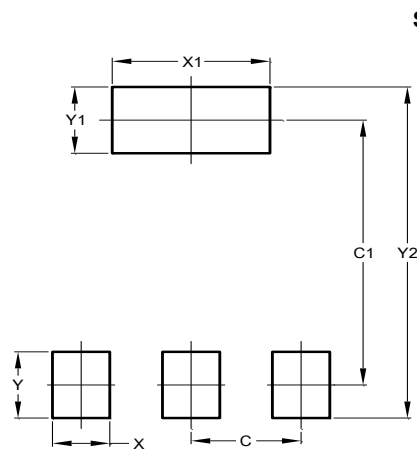

Dimensions	Value (in mm)
C	2.30
C1	6.40
X	1.20
X1	3.30
Y	1.60
Y1	1.60
Y2	8.00