



YOUSHANG SEMICONDUCTOR

设计研发新型功率器件

各类小信号开关

中低压及高压大电流等场效应管

0755-83047638

ysbdt@szyoushang.cn

www.szyoushang.cn



企业微信二维码



企业QQ二维码

Description

The NK-ZXTR2008Z monolithically integrates a transistor, Zener diode and resistor to function as a high voltage linear regulator. The device regulates with an 8.2V nominal output at 15mA. It is designed for use in high voltage applications where standard linear regulators cannot be used. This function is fully integrated into a SOT89 package, minimizing PCB area and reducing number of components when compared with a multi-chip discrete solution.

Applications

Supply Voltage Regulation in:

- Startup Switch in DC-DC Converters
- Networking
- Telecommunications
- Power over Ethernet (PoE)

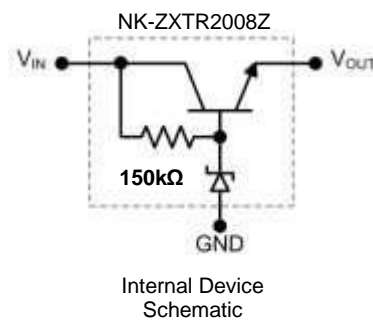

Features

- Series Linear Regulator Using Emitter-Follower Stage
- Input Voltage = 12V to 100V (For Regulated Output Voltage)
- Output Voltage = 8.2V ± 10%
- 150kΩ Resistor to Limit Quiescent Current
- Fully Integrated into a SOT89 package

Mechanical Data

- Case: SOT89
- Case Material: Molded Plastic. "Green" Molding Compound. UL Flammability Rating 94V-0
- Moisture Sensitivity: Level 1 per J-STD-020
- Terminals: Finish - Matte Tin Plated Leads, Solderable per MIL-STD-202, Method 208
- Weight: 0.052 grams (Approximate)

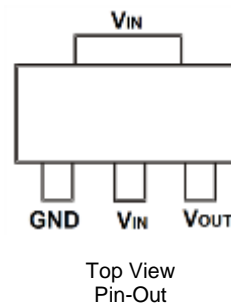

Pin Name	Pin Function
V _{IN}	Input Supply
GND	Power Ground
V _{OUT}	Voltage Output

Absolute Maximum Ratings (Voltage relative to GND, @ $T_A = +25^\circ\text{C}$, unless otherwise specified.)

Characteristic	Symbol	Value	Unit
Input Voltage	V_{IN}	-0.3 to 100	V
Continuous Input & Output Current	I_{IN}, I_{OUT}	400	mA
Peak Pulsed Input & Output Current	I_{IM}, I_{OM}	2	A
Maximum Voltage applied to V_{OUT}	$V_{OUT(MAX)}$	Smaller of $V_{IN}+8.2\text{V}$ or 14.5V	V

Maximum Current at $V_{IN} = 48\text{V}$ (@ $T_A = +25^\circ\text{C}$, unless otherwise specified.)

Characteristic		Symbol	Value	Unit
Continuous Output Current	(Note 7)	I_{OUT}	42	mA
Pulsed Output Current	(Note 8)	I_{OM}	800	mA
	(Note 9)		160	

Thermal Characteristics

Characteristic		Symbol	Value	Unit
Power Dissipation	(Note 5)	P_D	1.7	W
	(Note 6)		0.89	
Thermal Resistance, Junction to Ambient	(Note 5)	$R_{\theta JA}$	59	$^\circ\text{C/W}$
	(Note 6)		112	
Thermal Resistance, Junction to Lead	(Note 10)	$R_{\theta JL}$	20	
Thermal Resistance, Junction to Case	(Note 10)	$R_{\theta JC}$	15.7	
Recommended Operating Junction Temperature Range		T_J	-40 to +125	
Maximum Operating Junction and Storage Temperature Range		T_J, T_{STG}	-65 to +150	$^\circ\text{C}$

ESD Ratings (Note 11)

Characteristics	Symbols	Value	Unit	JEDEC Class
Electrostatic Discharge – Human Body Model	ESD HBM	4,000	V	3A
Electrostatic Discharge – Machine Model	ESD MM	400	V	C

- Notes:
- For a device mounted with the exposed V_{IN} pad on 50mm x 50mm 1oz copper that is on a single-sided 1.6mm FR4 PCB; device is measured under still air conditions whilst operating in steady-state.
 - Same as Note 5, except mounted on 15mm x 15mm 1oz copper.
 - Same as Note 5, whilst operating at $V_{IN} = 48\text{V}$. Refer to Safe Operating Area for other Input Voltages.
 - Same as Note 5, except measured with a single pulse width = 100 μs and $V_{IN} = 48\text{V}$.
 - Same as Note 5, except measured with a single pulse width = 10ms and $V_{IN} = 48\text{V}$.
 - $R_{\theta JL}$ = Thermal resistance from junction to solder-point (on the exposed V_{IN} pad). $R_{\theta JC}$ = Thermal resistance from junction to the top of case.
 - Refer to JEDEC specification JESD22-A114 and JESD22-A115.

Thermal Characteristics and Derating Information

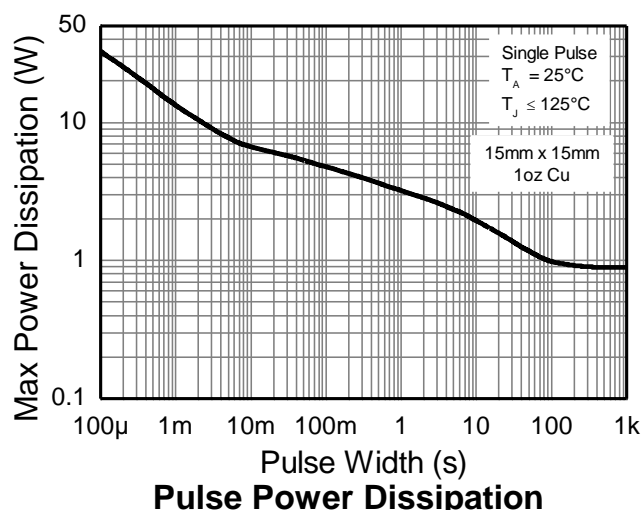
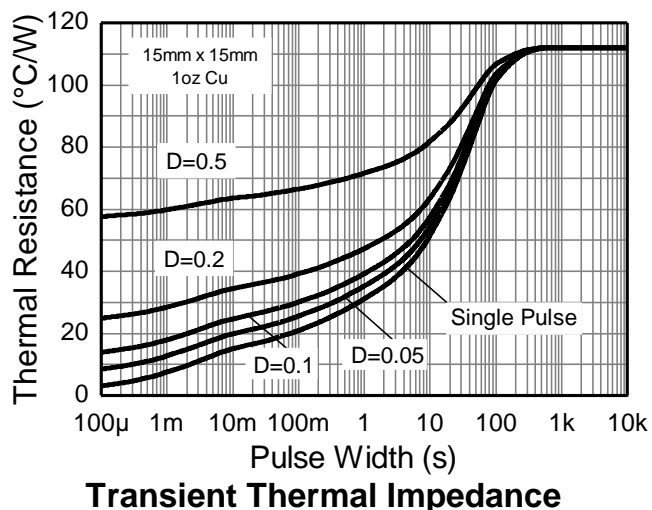
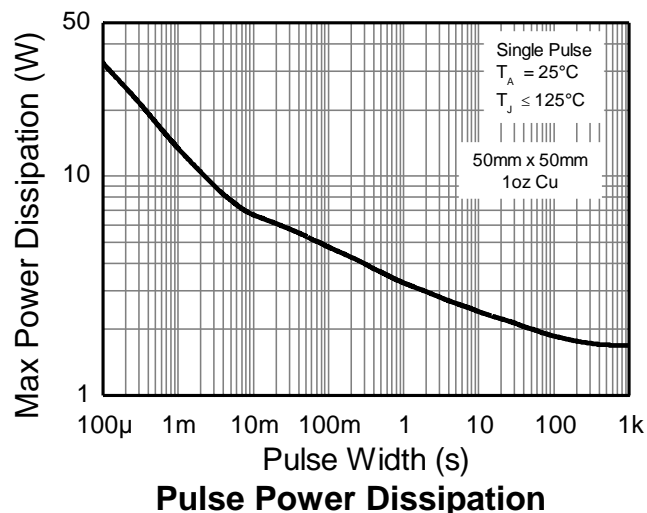
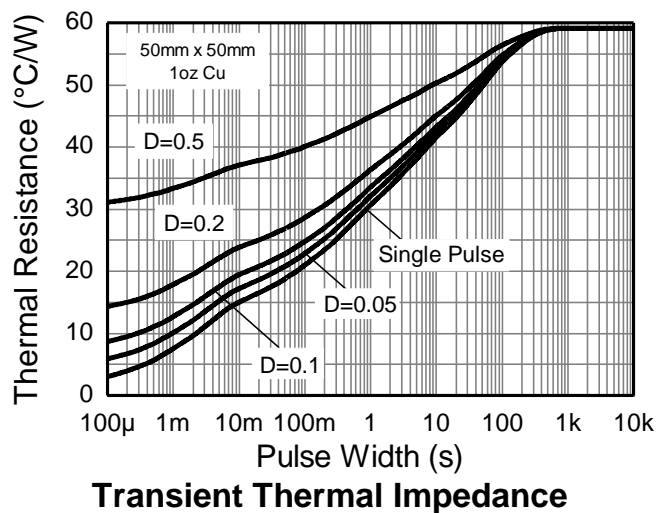
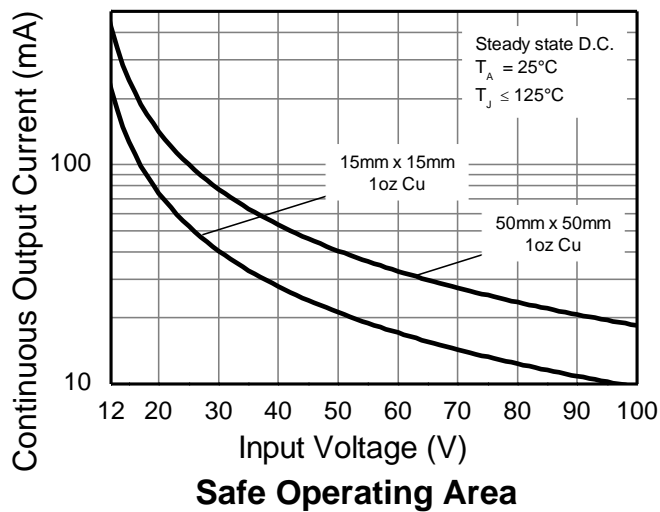
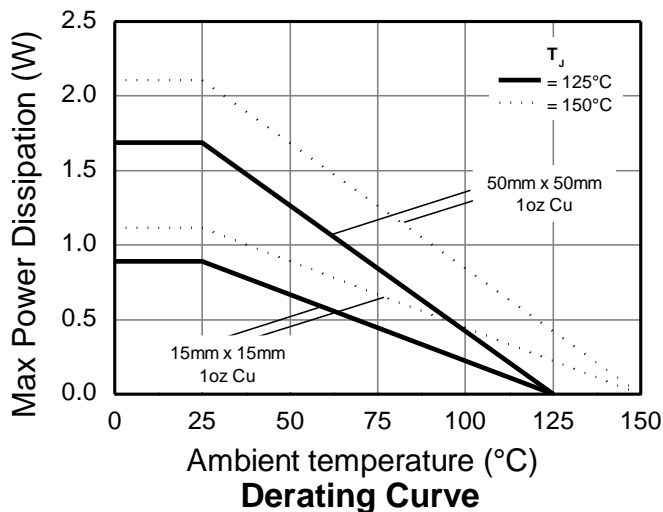

Electrical Characteristics (@ $T_A = +25^\circ\text{C}$, unless otherwise specified.)

Characteristic	Symbol	Min	Typ	Max	Unit	Test Condition
Output Voltage (Note 12)	V_{OUT}	7.38	8.2	9.02	V	$V_{IN} = 48\text{V}$, $I_{OUT} = 15\text{mA}$
Line Regulation (Notes 12 & 13)	ΔV_{OUT}	—	10	300	mV	$V_{IN} = 12$ to 100V, $I_{OUT} = 15\text{mA}$
Temperature Coefficient	$\Delta V_{OUT}/\Delta T$	—	10	—	mV/ $^\circ\text{C}$	$T_J = -40^\circ\text{C}$ to $+125^\circ\text{C}$ $V_{IN} = 48\text{V}$, $I_{OUT} = 15\text{mA}$
Load Regulation (Notes 12 & 14)	ΔV_{OUT}	—	-180 -250	-350 -500	mV	$I_{OUT} = 0.1$ to 30mA, $V_{IN} = 48\text{V}$ $I_{OUT} = 0.1$ to 100mA, $V_{IN} = 48\text{V}$
Minimum Value of Input Voltage Required to Maintain Line Regulation	$V_{IN(MIN)}$	12	—	—	V	—
Quiescent Current	I_Q	—	275 650	500 900	μA	$V_{IN} = 48\text{V}$, $I_{OUT} = 10\mu\text{A}$ $V_{IN} = 100\text{V}$, $I_{OUT} = 10\mu\text{A}$
Power Supply Rejection Ratio	$\Delta V_{IN}/\Delta V_{OUT}$	—	38	—	dB	$C_{OUT} = 100\text{nF}$, $I_{OUT} = 15\text{mA}$, $V_{OUT} = 8.2\text{V}$, $V_{IN} = 12$ to 100V, $f = 100\text{Hz}$

- Notes:
- 12. Measured under pulsed conditions. Pulse width $\leq 300\mu\text{s}$. Duty cycle $\leq 2\%$
 - 13. Line regulation $\Delta V_{OUT} = V_{OUT}(@ V_{IN} = 100\text{V}) - V_{OUT}(@ V_{IN} = 12\text{V})$
 - 14. Load regulation $\Delta V_{OUT} = V_{OUT}(@ I_{OUT} = 30\text{mA}) - V_{OUT}(@ I_{OUT} = 0.1\text{mA})$
 $\Delta V_{OUT} = V_{OUT}(@ I_{OUT} = 100\text{mA}) - V_{OUT}(@ I_{OUT} = 0.1\text{mA})$

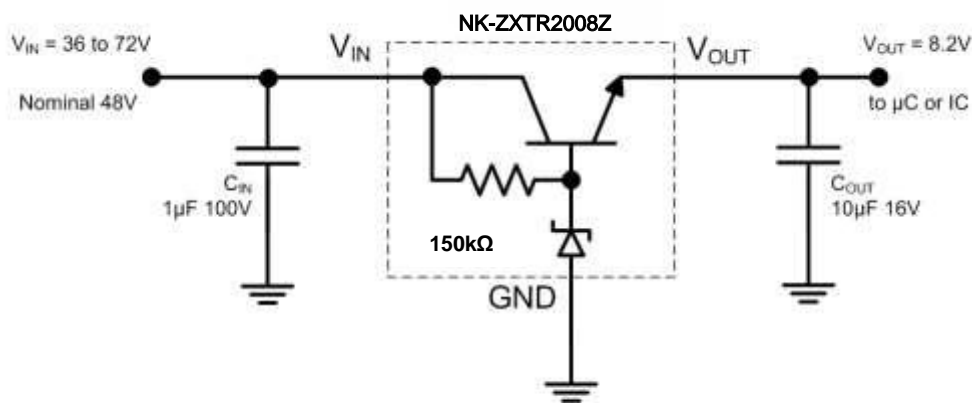
Typical Application Circuit

Example of an 8.2V regulated supply from a nominal 48V for powering a Controller IC.

Pin Functions

Pin Name	Pin Function	Notes
V_{IN}	Input Supply	Input voltage can vary from -0.3V to 100V with respect to GND; for V_{OUT} regulated then $12\text{V} \leq V_{IN} \leq 100\text{V}$. It is recommended to connect a $1\mu\text{F}$ capacitor to GND.
GND	Power Ground	This pin should be tied to the system ground.
V_{OUT}	Voltage Output	Outputs a regulated 8V when $12\text{V} \leq V_{IN} \leq 100\text{V}$. When $V_{IN} < 12\text{V}$, then V_{OUT} maximum = $V_{IN} - 1.5\text{V}$. The pin can be pulled high to a maximum of +14V with respect to GND, or +8V with respect to V_{IN} , whichever is lower. It is recommended to connect a $10\mu\text{F}$ capacitor to GND and a minimum of $10\mu\text{A}$ to be drawn from V_{OUT} to maintain regulation.

Typical Electrical Characteristics (@ $T_A = +25^\circ\text{C}$, unless otherwise specified.)

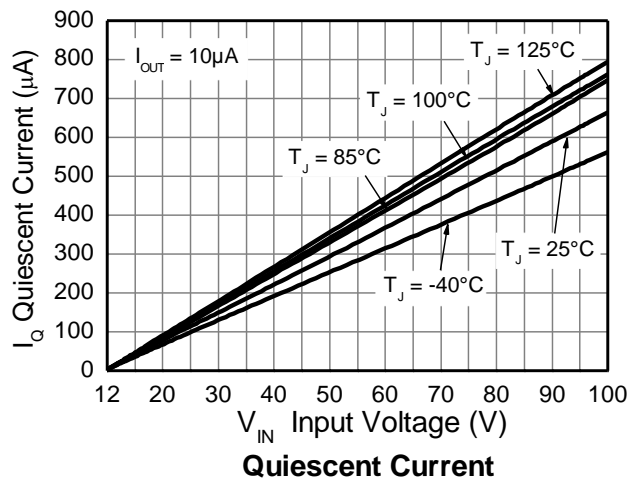
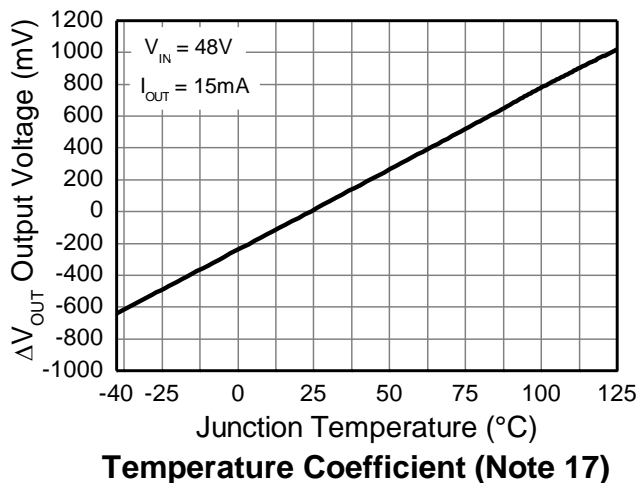
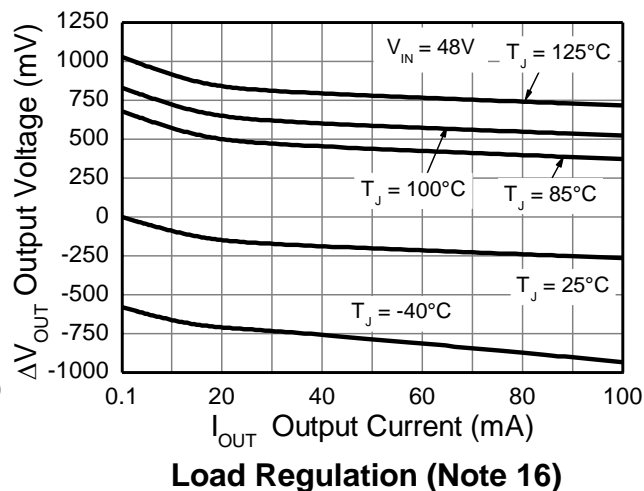
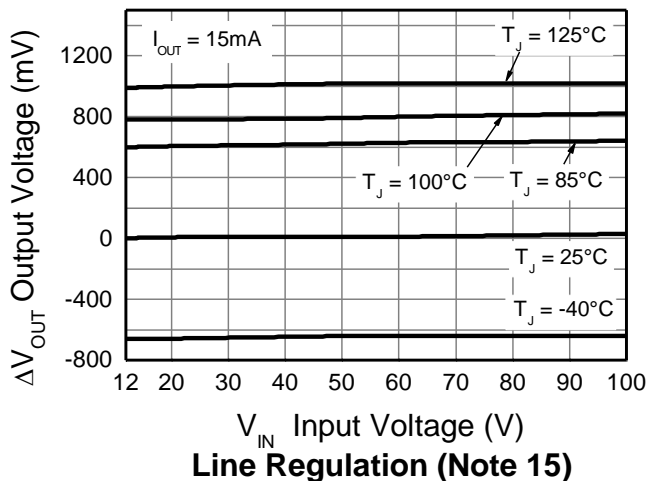
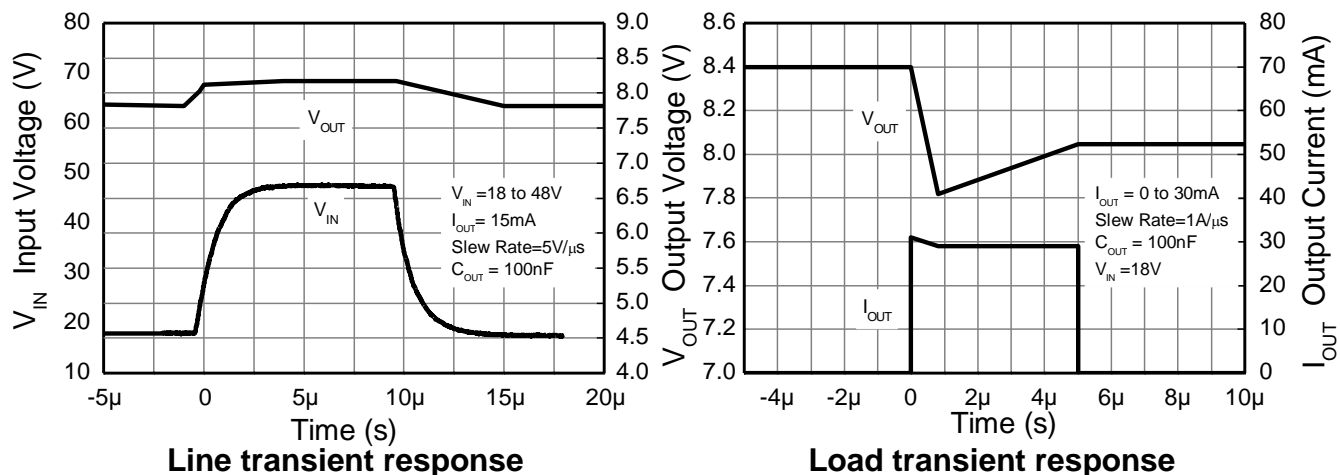

- Notes: 15. Line regulation $\Delta V_{OUT} = V_{OUT} - V_{OUT} (@ V_{IN} = 12\text{V}, I_{OUT} = 15\text{mA}, T_J = +25^\circ\text{C})$
 16. Load regulation $\Delta V_{OUT} = V_{OUT} - V_{OUT} (@ V_{IN} = 48\text{V}, I_{OUT} = 0.1\text{mA}, T_J = +25^\circ\text{C})$
 17. Temperature Coefficient $\Delta V_{OUT} = V_{OUT} - V_{OUT} (@ V_{IN} = 48\text{V}, I_{OUT} = 15\text{mA}, T_J = +25^\circ\text{C})$

Package Outline Dimensions

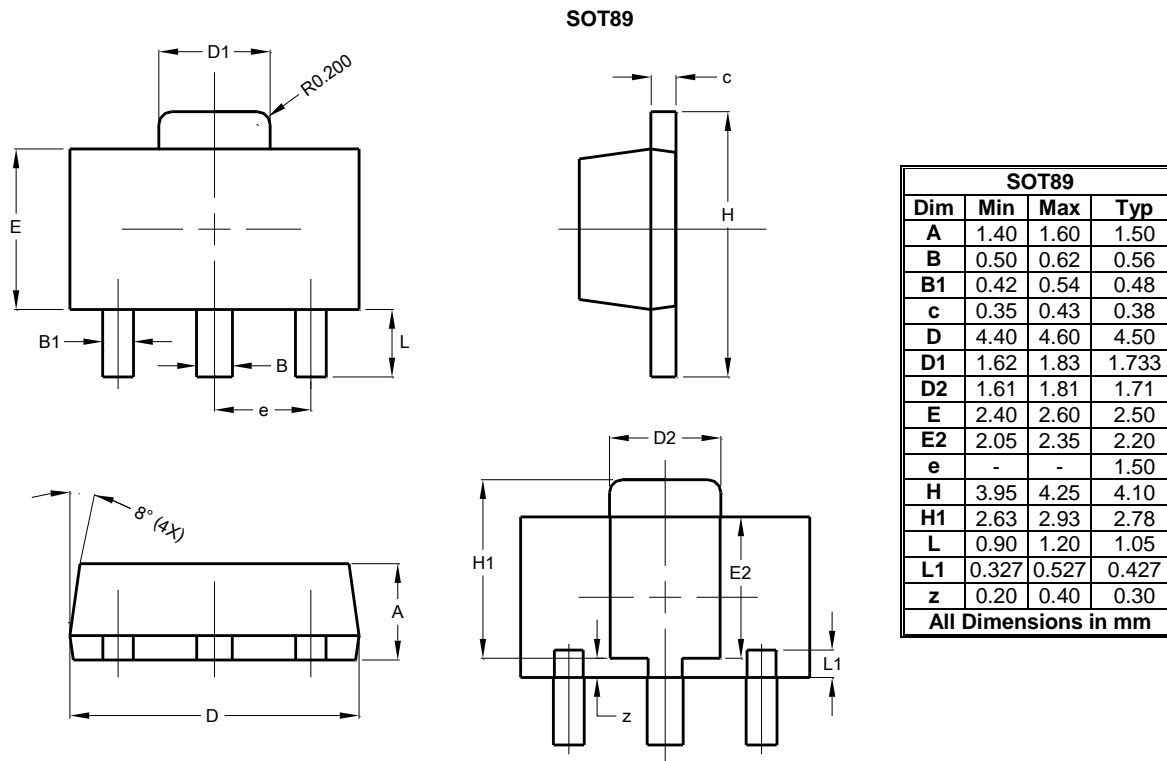

Suggested Pad Layout

