



YOUSHANG SEMICONDUCTOR

**设计研发新型功率器件**

**各类小信号开关**

**中低压及高压大电流等场效应管**

0755-83047638

ysbdt@szyoushang.cn

www.szyoushang.cn



企业微信二维码



企业QQ二维码

## Description

The NK-ZXTR2012FF monolithically integrates a transistor, Zener diode and resistor to function as a high-voltage linear regulator. The device regulates with a 12V nominal output at 15mA. It is designed for use in high-voltage applications where standard linear regulators cannot be used. This function is fully integrated into an SOT23F package, minimizing PCB area and reducing number of components when compared with a multi-chip discrete solution.

## Applications

Supply voltage regulation in:

- Networking
- Telecommunications
- Power over Ethernet (PoE)

## Features

- Series Linear Regulator Using Emitter-Follower Stage
- Input Voltage = 15V to 100V
- Output Voltage = 12V  $\pm$  10%
- Fully Integrated into a SOT23F Package

## Mechanical Data

- Case: SOT23F
- Case material: Molded Plastic. "Green" Molding Compound. UL Flammability Rating 94V-0
- Moisture Sensitivity: Level 1 per J-STD-020
- Terminals: Finish – Matte Tin Plated Leads. Solderable per MIL-STD-202, Method 208 
- Weight: 0.012 grams (Approximate)

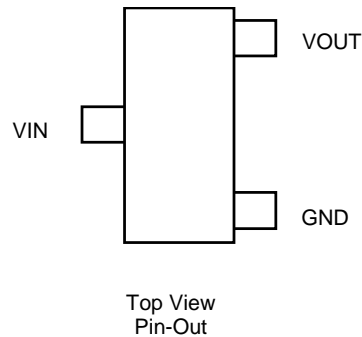
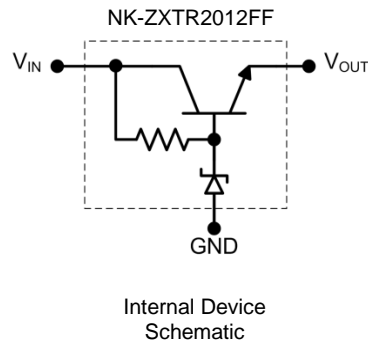
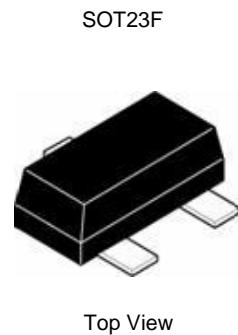

Pin Name	Pin Function
VIN	Input Supply
GND	Power Ground
VOUT	Voltage Output

**Absolute Maximum Ratings** (Voltage relative to GND, @ $T_A = +25^\circ\text{C}$ , unless otherwise specified.)

Characteristic	Symbol	Value	Unit
Input Supply Voltage	$V_{IN}$	-0.3 to 100	V
Continuous Input & Output Current	$I_{IN}, I_{OUT}$	550	mA
Peak Pulsed Input & Output Current	$I_{IM}, I_{OM}$	2	A
Maximum Voltage Applied to $V_{OUT}$	$V_{OUT(MAX)}$	18	V

**Maximum Current at  $V_{IN} = 48\text{V}$**  (@ $T_A = +25^\circ\text{C}$ , unless otherwise specified.)

Characteristic	Symbol	Value	Unit
Continuous Output Current	$I_{OUT}$	36	mA
Pulsed Output Current	$I_{OM}$	880	mA
		180	

**Thermal Characteristics**

Characteristic	Symbol	Value	Unit
Power Dissipation	$P_D$	1.3	W
		1	
Thermal Resistance, Junction to Ambient	$R_{\theta JA}$	95	$^\circ\text{C/W}$
		126	
Thermal Resistance, Junction to Lead	$R_{\theta JL}$	59	
Thermal Resistance, Junction to Case	$R_{\theta JC}$	38	
Maximum Operating Junction and Storage Temperature Range	$T_J, T_{STG}$	-65 to +150	$^\circ\text{C}$

**ESD Ratings** (Note 11)

Characteristics	Symbols	Value	Unit	JEDEC Class
Electrostatic Discharge – Human Body Model	ESD HBM	4,000	V	3A
Electrostatic Discharge – Machine Model	ESD MM	400	V	C

- Notes:
- For a device mounted with the exposed  $V_{IN}$  pad on 25mm x 25mm 1oz copper that is on a single-sided 1.6mm FR-4 PCB; device is measured under still air conditions whilst operating in steady-state.
  - Same as note 5, except mounted on 15mm x 15mm 1oz copper.
  - Same as note 5, whilst operating at  $V_{IN} = 48\text{V}$ . Refer to Safe Operating Area for other Input Voltages.
  - Same as note 5, except measured with a single pulse width = 100 $\mu\text{s}$  and  $V_{IN} = 48\text{V}$ .
  - Same as note 5, except measured with a single pulse width = 10ms and  $V_{IN} = 48\text{V}$ .
  - $R_{\theta JL}$  = Thermal resistance from junction to solder-point (on the exposed  $V_{IN}$  pad).
  - $R_{\theta JC}$  = Thermal resistance from junction to the top of case.
  - Refer to JEDEC specification JESD22-A114 and JESD22-A115.

**Thermal Characteristics and Derating Information**

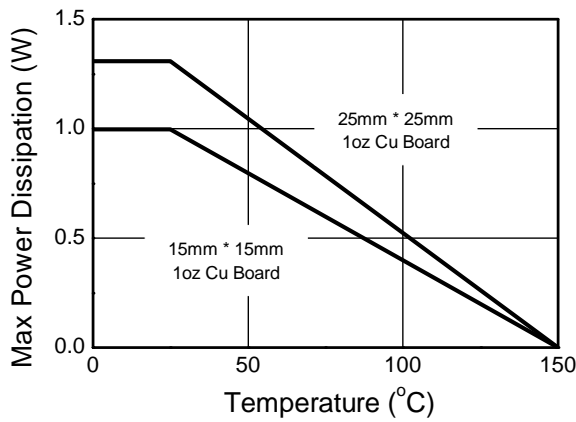

**Derating Curve**

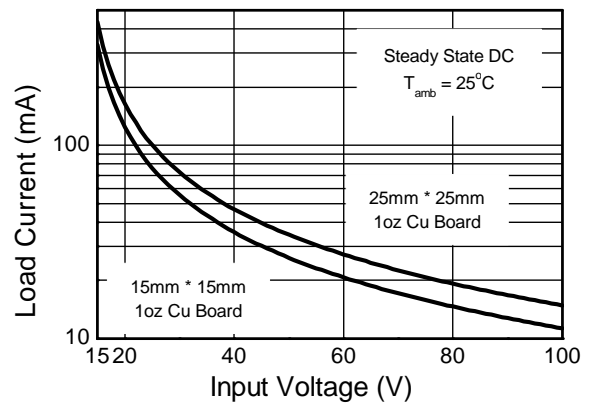

**Safe Operating Area**

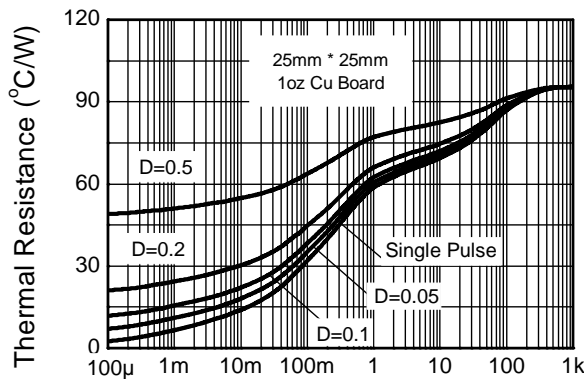

**Transient Thermal Impedance**

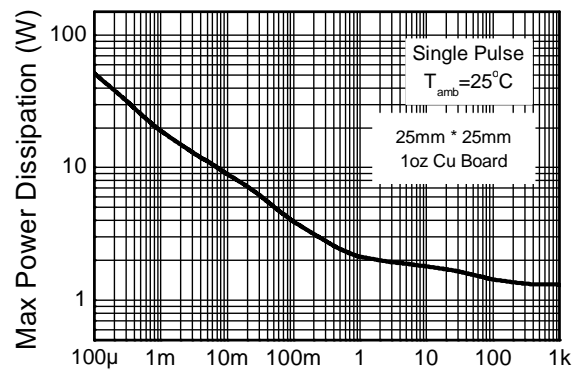

**Pulse Power Dissipation**

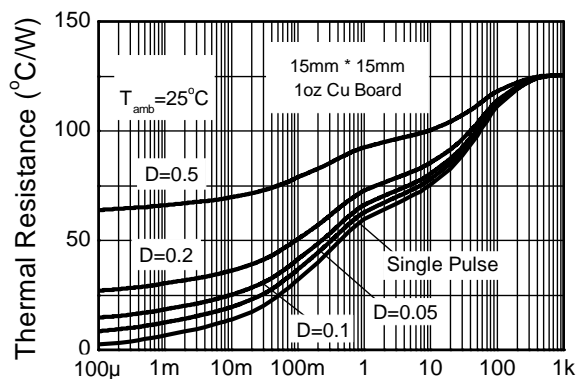

**Transient Thermal Impedance**

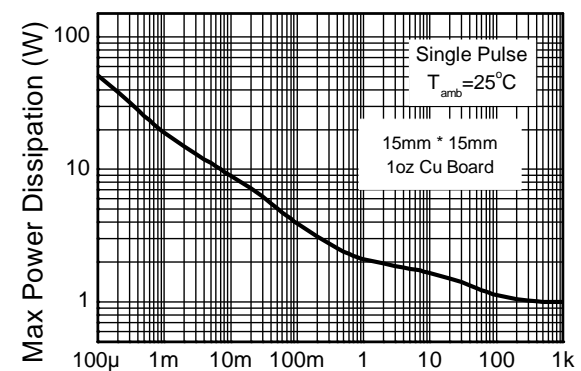

**Pulse Power Dissipation**

**Electrical Characteristics** (@T<sub>A</sub> = +25°C, unless otherwise specified.)

Characteristic	Symbol	Min	Typ	Max	Unit	Test Condition
Output Voltage (Note 12)	V <sub>OUT</sub>	10.8	12	13.2	V	V <sub>IN</sub> = 48V, I <sub>OUT</sub> = 15mA
Line Regulation (Notes 12 & 13)	ΔV <sub>OUT</sub>	—	240	750	mV	V <sub>IN</sub> = 15V to 72V, I <sub>OUT</sub> = 15mA
Temperature Coefficient	ΔV <sub>OUT</sub> /ΔT	—	8.0	—	mV/°C	T <sub>J</sub> = -40°C to +125°C V <sub>IN</sub> = 48V, I <sub>OUT</sub> = 15mA
Load Regulation (Notes 12 & 14)	ΔV <sub>OUT</sub>	—	-450 -600	-600 -750	mV	I <sub>OUT</sub> = 0.1mA to 30mA, V <sub>IN</sub> = 48V I <sub>OUT</sub> = 0.1mA to 100mA, V <sub>IN</sub> = 48V
Minimum Value of Input Voltage Required to Maintain Line Regulation	V <sub>IN(MIN)</sub>	15	—	—	V	—
Quiescent Current	I <sub>Q</sub>	—	240 590	400 900	μA	V <sub>IN</sub> = 48V, I <sub>OUT</sub> = 10μA V <sub>IN</sub> = 100V, I <sub>OUT</sub> = 10μA
Power Supply Rejection Ratio	ΔV <sub>IN</sub> /ΔV <sub>OUT</sub>	—	45	—	dB	C <sub>OUT</sub> = 100nF, I <sub>OUT</sub> = 15mA, V <sub>OUT</sub> = 12V, V <sub>IN</sub> = 15V to 100V, f = 100Hz

Notes:

12. Measured under pulsed conditions. Pulse width ≤ 300μs. Duty cycle ≤ 2%.
13. Line regulation ΔV<sub>OUT</sub> = V<sub>OUT</sub>(@ V<sub>IN</sub> = 72V) - V<sub>OUT</sub>(@ V<sub>IN</sub> = 15V).
14. Load regulation ΔV<sub>OUT</sub> = V<sub>OUT</sub>(@ I<sub>OUT</sub> = 30mA) - V<sub>OUT</sub>(@ I<sub>OUT</sub> = 0.1mA).  
ΔV<sub>OUT</sub> = V<sub>OUT</sub>(@ I<sub>OUT</sub> = 100mA) - V<sub>OUT</sub>(@ I<sub>OUT</sub> = 0.1mA).

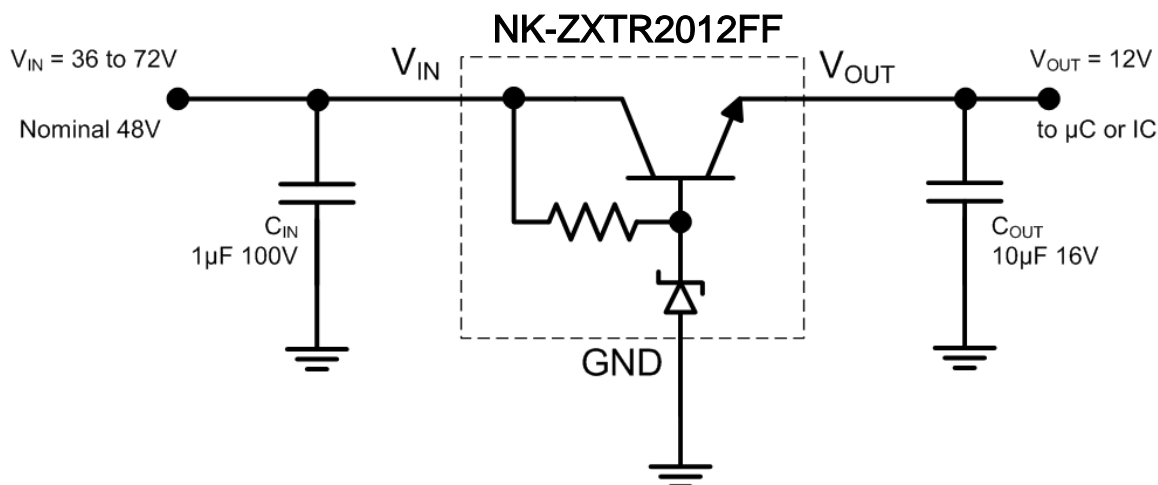
**Typical Application Circuit**

Example of an 12V regulated supply from a nominal 48V for powering a Controller IC.

**Pin Functions**

Pin Name	Pin Function	Notes
V <sub>IN</sub>	Input Supply	To maintain output regulation the input voltage can vary from 15V to 100V with respect to the GND pin. It is recommended to connect a 1μF capacitor to GND.
GND	Power Ground	This pin should be tied to the system ground.
V <sub>OUT</sub>	Voltage Output	Outputs a regulated 12V. It is recommended to connect a 10μF capacitor to GND. Minimum of 10μA must be drawn from V <sub>OUT</sub> to maintain regulation. The pin can be pulled high to a maximum of 18V with respect to ground.

Typical Electrical Characteristics (@ $T_A = +25^\circ\text{C}$ , unless otherwise specified.)

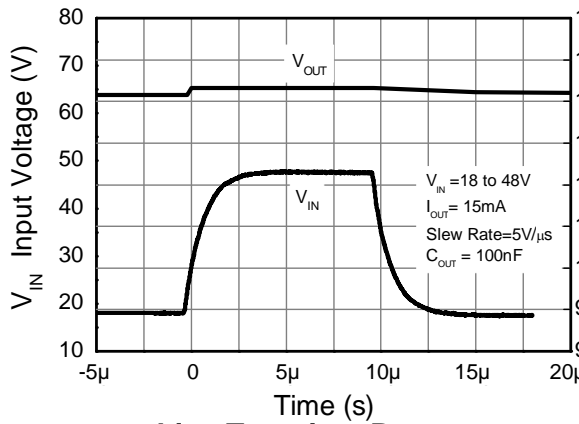

Line Transient Response

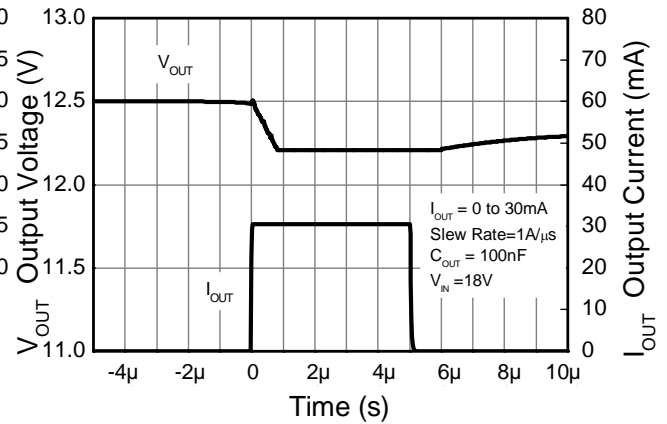

Load Transient Response

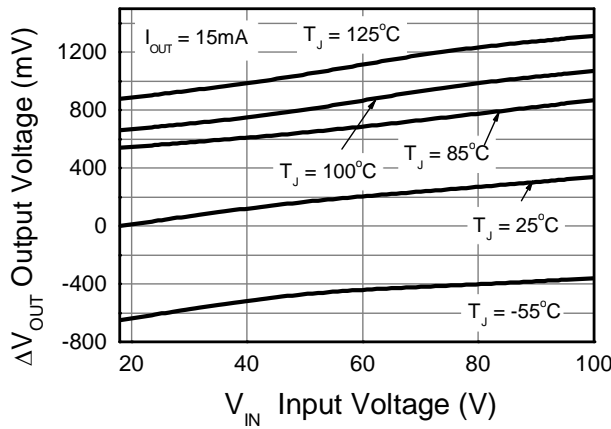

Line Regulation (Note 15)

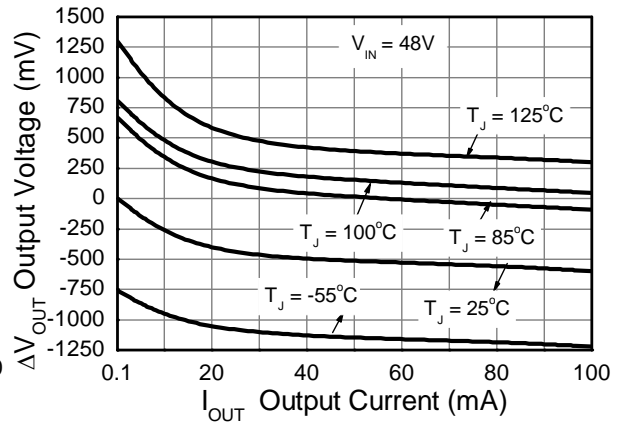

Load Regulation (Note 16)

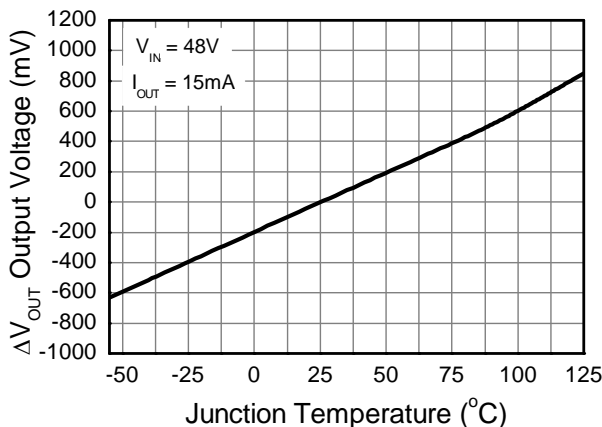

Temperature Coefficient (Note 17)

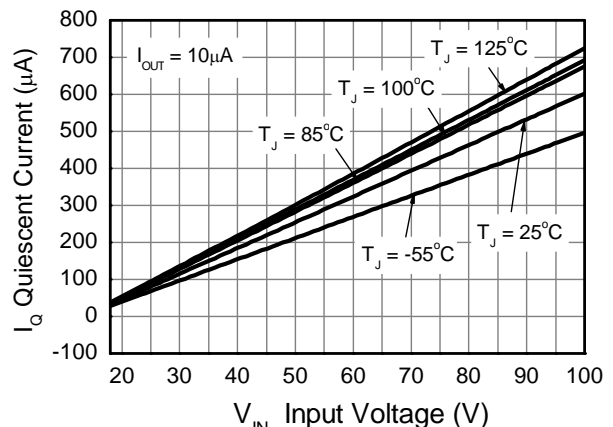

Quiescent Current

Notes: 15. Line regulation  $\Delta V_{OUT} = V_{OUT} - V_{OUT}$  (@  $V_{IN} = 15\text{V}$ ,  $I_{OUT} = 15\text{mA}$ ,  $T_J = +25^\circ\text{C}$ ).  
 16. Load regulation  $\Delta V_{OUT} = V_{OUT} - V_{OUT}$  (@  $V_{IN} = 48\text{V}$ ,  $I_{OUT} = 0.1\text{mA}$ ,  $T_J = +25^\circ\text{C}$ ).  
 17. Temperature Coefficient  $\Delta V_{OUT} = V_{OUT} - V_{OUT}$  (@  $V_{IN} = 48\text{V}$ ,  $I_{OUT} = 15\text{mA}$ ,  $T_J = +25^\circ\text{C}$ ).

Package Outline Dimensions

SOT23F

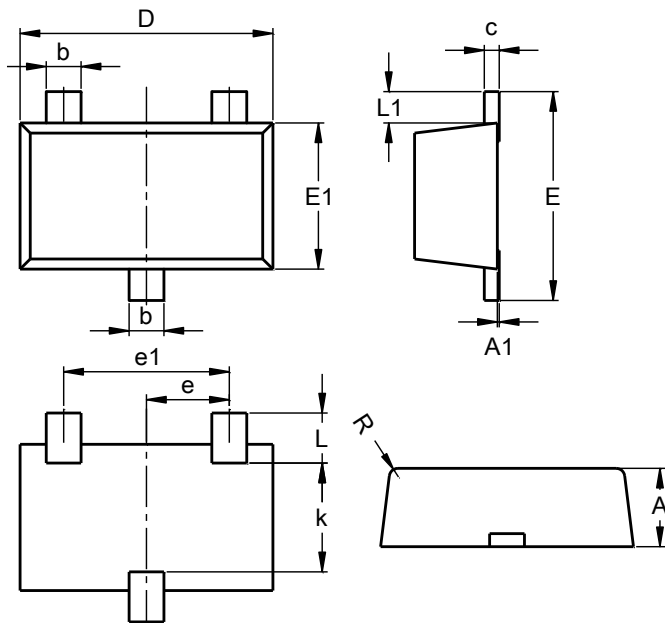

SOT23F			
Dim	Min	Max	Typ
A	0.80	1.00	0.90
A1	0.00	0.10	0.01
b	0.35	0.50	0.44
c	0.10	0.20	0.16
D	2.80	3.00	2.90
e	0.95 REF		
e1	1.90 REF		
E	2.30	2.50	2.40
E1	1.50	1.70	1.65
k	1.20	-	-
L	0.30	0.65	0.50
L1	0.30	0.50	0.40
R	0.05	0.15	-
All Dimensions in mm			

Suggested Pad Layout

SOT23F

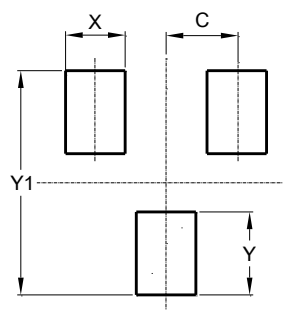

Dimensions	Value (in mm)
C	0.95
X	0.80
Y	1.110
Y1	3.000