



YOUSHANG SEMICONDUCTOR

设计研发新型功率器件

各类小信号开关

中低压及高压大电流等场效应管

0755-83047638

ysbdt@szyoushang.cn

www.szyoushang.cn



企业微信二维码



企业QQ二维码

Description

The NK-ZXTR2012P5 monolithically integrates a transistor, zener diode and resistor to function as a high-voltage linear regulator. The device regulates with a 12V nominal output at 15mA. It is designed for use in high-voltage applications where standard linear regulators cannot be used. This function is fully integrated into a PowerDI5 package, minimizing PCB area and reducing number of components when compared with a multi-chip discrete solution.

Applications

Supply voltage regulation in:

- Startup switch in DC-DC converters
- Networking
- Telecommunications
- Power over Ethernet (PoE)

Features

- Series Linear Regulator Using Emitter-Follower Stage
- Input Voltage = 15V to 100V (For regulated output voltage)
- Output Voltage = 12V \pm 10%
- 150k Ω resistor to limit quiescent current
- Fully integrated into a PowerDI5 package

Mechanical Data

- Case: PowerDI5
- Case Material: Molded Plastic, "Green" Molding Compound.
- UL Flammability Rating 94V-0
- Moisture Sensitivity: Level 1 per J-STD-020
- Terminals: Finish - Matte Tin Plated Leads.
Solderable per MIL-STD-202, Method 208 
- Weight: 0.100 grams (Approximate)

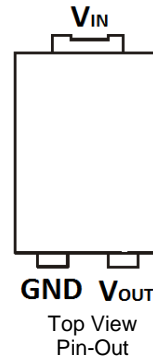
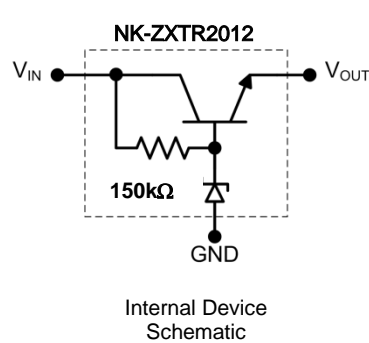
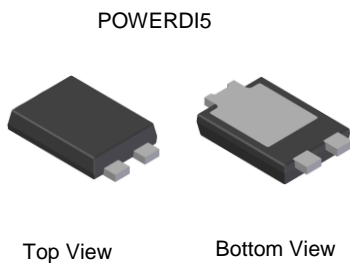

| Pin Name | Pin Function |
|------------------|----------------|
| V _{IN} | Input Supply |
| GND | Power Ground |
| V _{OUT} | Voltage Output |

Absolute Maximum Ratings

 (Voltage relative to GND, @ $T_A = +25^\circ\text{C}$, unless otherwise specified.)

| Characteristic | Symbol | Value | Unit |
|--------------------------------------|-------------------|---------------------------------------|------|
| Input Supply Voltage | V_{IN} | -0.3 to 100 | V |
| Continuous Input & Output Current | I_{IN}, I_{OUT} | 550 | mA |
| Peak Pulsed Input & Output Current | I_{IM}, I_{OM} | 2 | A |
| Maximum Voltage applied to V_{OUT} | $V_{OUT(max)}$ | Smaller of $V_{IN}+12\text{V}$ or 18V | V |

Maximum Current at $V_{IN} = 48\text{V}$

 (@ $T_A = +25^\circ\text{C}$, unless otherwise specified.)

| Characteristic | Symbol | Value | Unit |
|---------------------------|-----------|-------|------|
| Continuous Output Current | I_{OUT} | 50 | mA |
| Pulsed Output Current | I_{OM} | 880 | mA |
| | | 180 | |

Thermal Characteristics

| Characteristic | Symbol | Value | Unit |
|--|-----------------|-------------|--------------------|
| Power Dissipation | P_D | 1.82 | W |
| | | 0.94 | |
| Thermal Resistance, Junction to Ambient | $R_{\theta JA}$ | 55 | $^\circ\text{C/W}$ |
| | | 107 | |
| Thermal Resistance, Junction to Lead | $R_{\theta JL}$ | 20 | |
| Thermal Resistance, Junction to Case | $R_{\theta JC}$ | 17.8 | |
| Recommended Operating Junction Temperature Range | T_J | -40 to +125 | $^\circ\text{C}$ |
| Maximum Operating Junction and Storage Temperature Range | T_J, T_{STG} | -65 to +150 | |

ESD Ratings

 (Note 11)

| Characteristics | Symbols | Value | Unit | JEDEC Class |
|--|---------|-------|------|-------------|
| Electrostatic Discharge – Human Body Model | ESD HBM | 4000 | V | 3A |
| Electrostatic Discharge – Machine Model | ESD MM | 400 | V | C |

- Notes:
- For a device mounted with the exposed V_{IN} pad on 50mm x 50mm 1oz copper that is on a single-sided 1.6mm FR4 PCB; device is measured under still air conditions whilst operating in steady-state.
 - Same as Note 5, except mounted on 15mm x 15mm 1oz copper.
 - Same as Note 5, whilst operating at $V_{IN} = 48\text{V}$. Refer to Safe Operating Area for other Input Voltages.
 - Same as Note 5, except measured with a single pulse width = 100 μs and $V_{IN} = 48\text{V}$.
 - Same as Note 5, except measured with a single pulse width = 10ms and $V_{IN} = 48\text{V}$.
 - $R_{\theta JL}$ = Thermal resistance from junction to solder-point (on the exposed V_{IN} pad).
 - $R_{\theta JC}$ = Thermal resistance from junction to the top of case.
 - Refer to JEDEC specification JESD22-A114 and JESD22-A115.

Thermal Characteristics and Derating Information

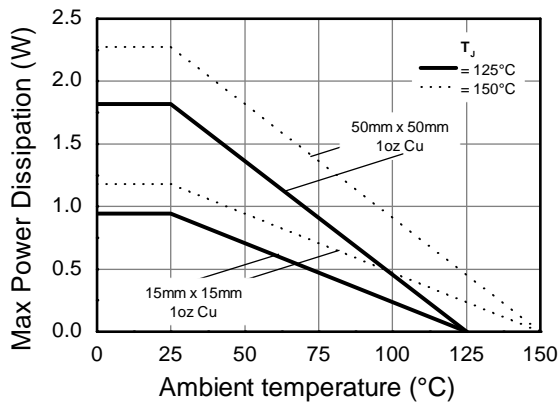

Derating Curve

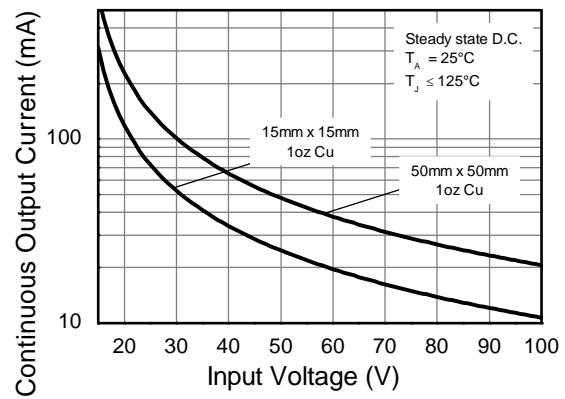

Safe Operating Area

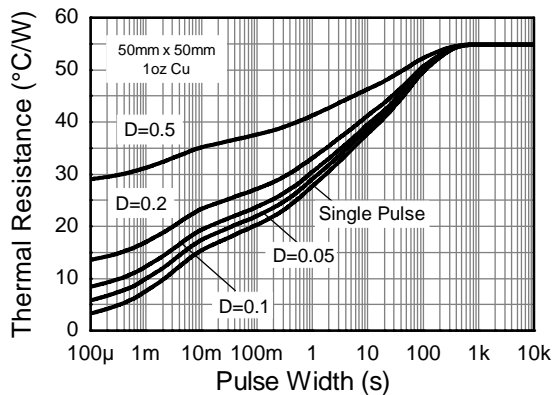

Transient Thermal Impedance

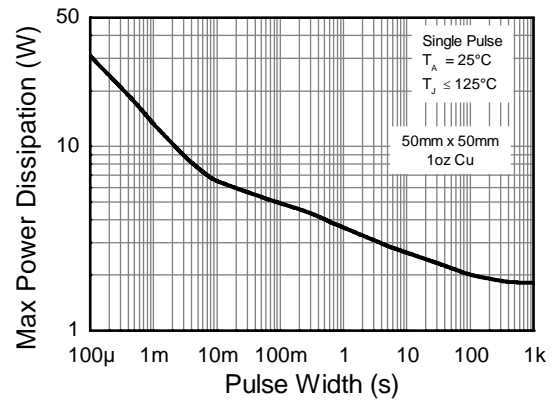

Pulse Power Dissipation

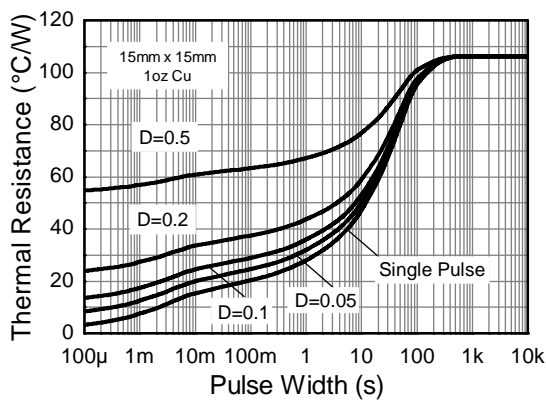

Transient Thermal Impedance

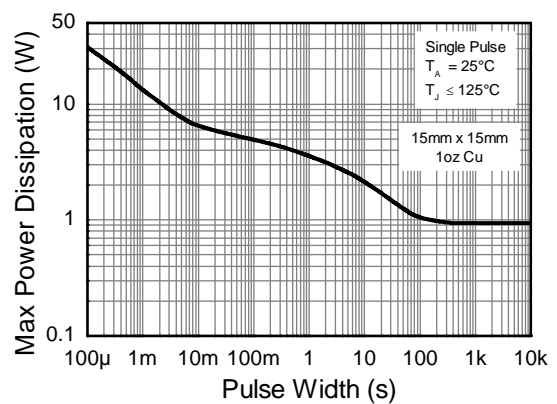

Pulse Power Dissipation

Electrical Characteristics (@ $T_A = +25^\circ\text{C}$, unless otherwise specified.)

| Characteristic | Symbol | Min | Typ | Max | Unit | Test Condition |
|---|--------------------------------|------|--------------|--------------|----------------------|--|
| Output Voltage (Note 12) | V_{OUT} | 10.8 | 12 | 13.2 | V | $V_{IN} = 48\text{V}$, $I_{OUT} = 15\text{mA}$ |
| Line Regulation (Notes 12 & 13) | ΔV_{OUT} | — | 240 | 750 | mV | $V_{IN} = 15$ to 72V , $I_{OUT} = 15\text{mA}$ |
| Temperature Coefficient | $\Delta V_{OUT}/\Delta T$ | — | 8.0 | — | mV/ $^\circ\text{C}$ | $T_J = -40^\circ\text{C}$ to $+125^\circ\text{C}$ $V_{IN} = 48\text{V}$, $I_{OUT} = 15\text{mA}$ |
| Load Regulation (Notes 12 & 14) | ΔV_{OUT} | — | -450 -600 | -600 -750 | mV | $I_{OUT} = 0.1$ to 30mA , $V_{IN} = 48\text{V}$ $I_{OUT} = 0.1$ to 100mA , $V_{IN} = 48\text{V}$ |
| Minimum Value of Input Voltage Required to Maintain Line Regulation | $V_{IN(MIN)}$ | 15 | — | — | V | — |
| Quiescent Current | I_Q | — | 240 590 | 400 900 | μA | $V_{IN} = 48\text{V}$, $I_{OUT} = 10\mu\text{A}$ $V_{IN} = 100\text{V}$, $I_{OUT} = 10\mu\text{A}$ |
| Power Supply Rejection Ratio | $\Delta V_{IN}/\Delta V_{OUT}$ | — | 45 | — | dB | $C_{OUT} = 100\text{nF}$, $I_{OUT} = 15\text{mA}$, $V_{OUT} = 12\text{V}$, $V_{IN} = 15$ to 100V , $f = 100\text{Hz}$ |

Notes:

12. Measured under pulsed conditions. Pulse width $\leq 300\mu\text{s}$. Duty cycle $\leq 2\%$.
13. Line regulation $\Delta V_{OUT} = V_{OUT}(@ V_{IN} = 72\text{V}) - V_{OUT}(@ V_{IN} = 15\text{V})$
14. Load regulation $\Delta V_{OUT} = V_{OUT}(@ I_{OUT} = 30\text{mA}) - V_{OUT}(@ I_{OUT} = 0.1\text{mA})$
 $\Delta V_{OUT} = V_{OUT}(@ I_{OUT} = 100\text{mA}) - V_{OUT}(@ I_{OUT} = 0.1\text{mA})$

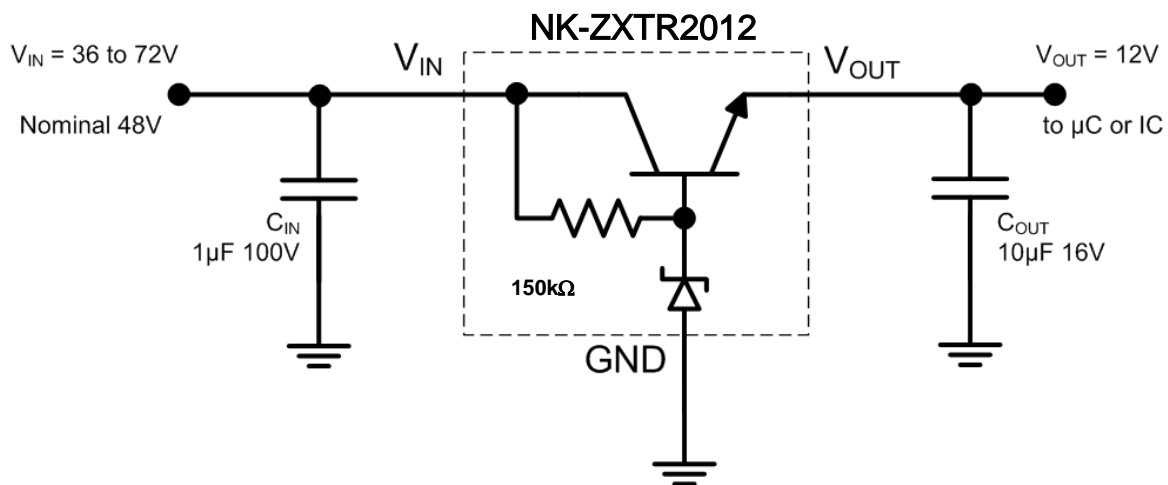
Typical Application Circuit

Example of an 12V regulated supply from a nominal 48V for powering a Controller IC.

Pin Functions

| Pin Name | Pin Function | Notes |
|----------|----------------|--|
| V_{IN} | Input Supply | Input voltage can vary from -0.3V to 100V with respect to GND; for V_{OUT} regulated then $15\text{V} \leq V_{IN} \leq 100\text{V}$. It is recommended to connect a $1\mu\text{F}$ capacitor to GND. |
| GND | Power Ground | This pin should be tied to the system ground. |
| VOUT | Voltage Output | Outputs a regulated 12V when $15\text{V} \leq V_{IN} \leq 100\text{V}$. When $V_{IN} < 15\text{V}$, then V_{OUT} maximum = $V_{IN} - 1.5\text{V}$. The pin can be pulled high to a maximum of $+18\text{V}$ with respect to GND, or $+12\text{V}$ with respect to V_{IN} , whichever is lower. It is recommended to connect a $10\mu\text{F}$ capacitor to GND and a minimum of $10\mu\text{A}$ to be drawn from V_{OUT} to maintain regulation. |

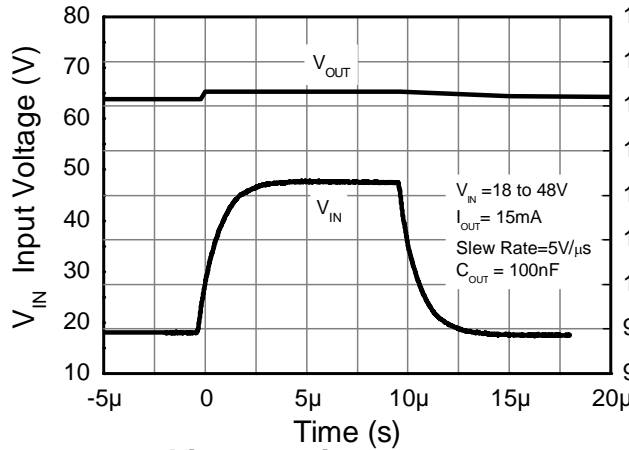
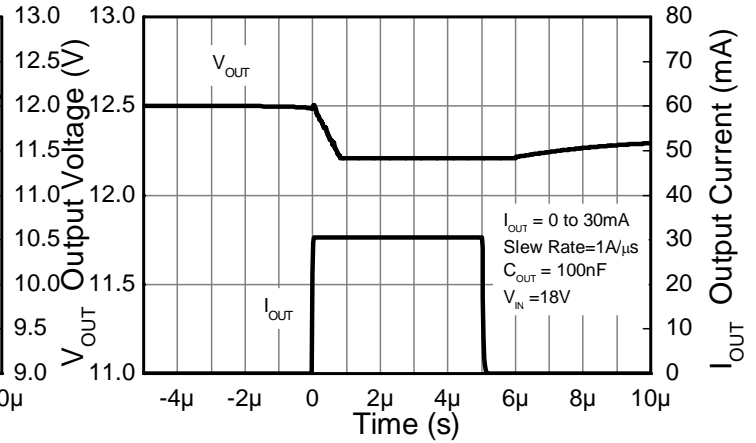
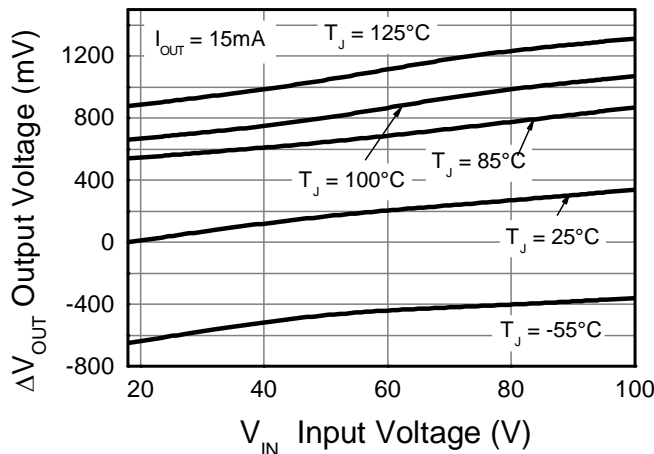
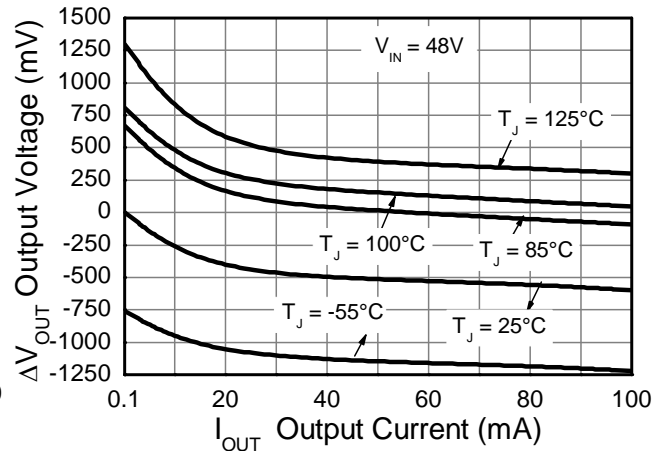
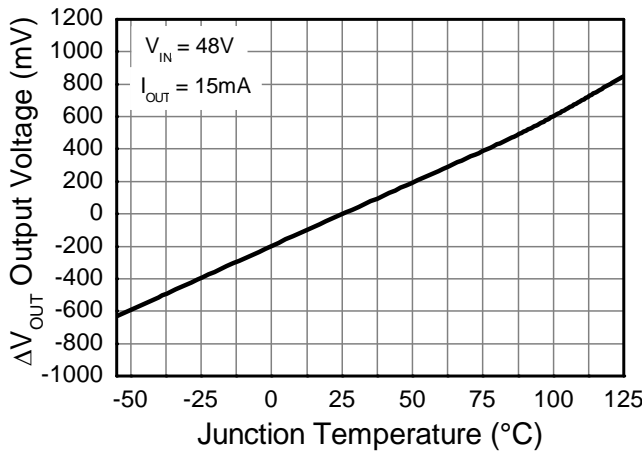
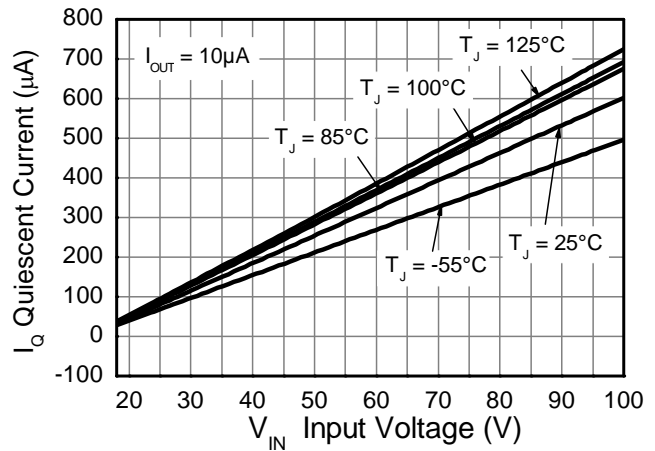
Typical Electrical Characteristics (@ $T_A = +25^\circ\text{C}$, unless otherwise specified.)

Line transient response

Load transient response

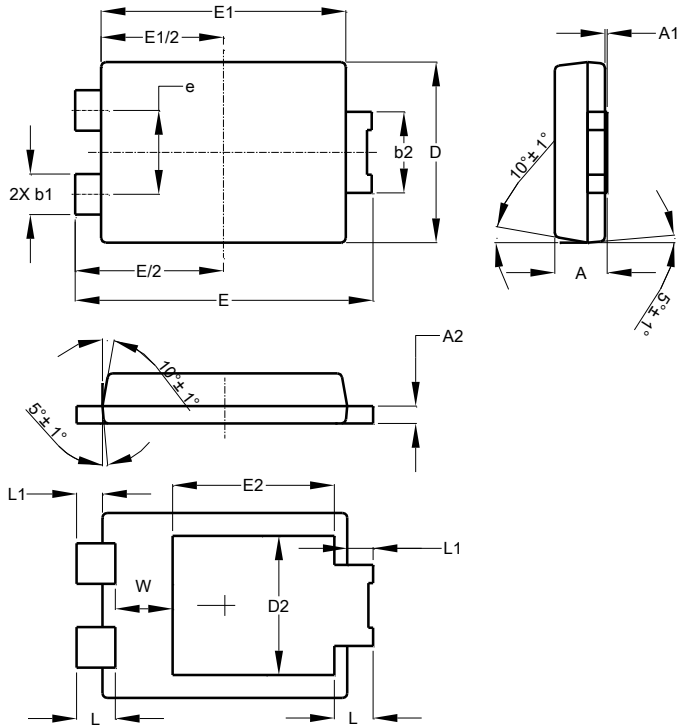
Line Regulation (Note 15)

Load Regulation (Note 16)

Temperature Coefficient (Note 17)

Quiescent Current

- Notes:
- Line regulation $\Delta V_{OUT} = V_{OUT} - V_{OUT}(@ V_{IN} = 15\text{V}, I_{OUT} = 15\text{mA}, T_J = +25^\circ\text{C})$
 - Load regulation $\Delta V_{OUT} = V_{OUT} - V_{OUT}(@ V_{IN} = 48\text{V}, I_{OUT} = 0.1\text{mA}, T_J = +25^\circ\text{C})$
 - Temperature Coefficient $\Delta V_{OUT} = V_{OUT} - V_{OUT}(@ V_{IN} = 48\text{V}, I_{OUT} = 15\text{mA}, T_J = +25^\circ\text{C})$

Package Outline Dimensions



| PowerDI5 | | | |
|----------------------|------|------|-------|
| Dim | Min | Max | Typ |
| A | 1.05 | 1.15 | 1.10 |
| A1 | 0.00 | 0.05 | -- |
| A2 | 0.33 | 0.43 | 0.381 |
| b1 | 0.80 | 0.99 | 0.89 |
| b2 | 1.70 | 1.88 | 1.78 |
| D | 3.90 | 4.05 | 3.966 |
| D2 | -- | -- | 3.054 |
| E | 6.40 | 6.60 | 6.504 |
| e | -- | -- | 1.84 |
| E1 | 5.30 | 5.45 | 5.37 |
| E2 | -- | -- | 3.549 |
| L | 0.75 | 0.95 | 0.85 |
| L1 | 0.50 | 0.65 | 0.57 |
| W | 1.10 | 1.41 | 1.255 |
| All Dimensions in mm | | | |

Suggested Pad Layout

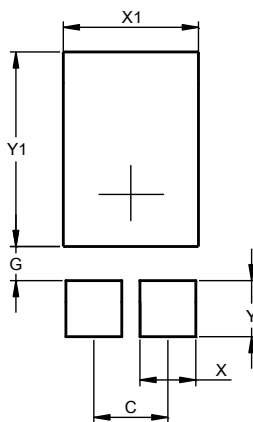

| Dimensions | Value (in mm) |
|------------|---------------|
| C | 1.840 |
| G | 0.852 |
| X | 1.390 |
| X1 | 3.360 |
| Y | 1.400 |
| Y1 | 4.860 |