



YOUSHANG SEMICONDUCTOR

设计研发新型功率器件

各类小信号开关

中低压及高压大电流等场效应管

0755-83047638
ysbdt@szyoushang.cn
www.szyoushang.cn



企业微信二维码



企业QQ二维码

Product Summary

| BV _{DSS} | R _{DS(ON)} Max | I _D Max T _A = +25°C |
|-------------------|-----------------------------|--|
| 30V | 3Ω @ V _{GS} = 4.5V | 250mA |
| | 5Ω @ V _{GS} = 4.0V | 200mA |
| | 7Ω @ V _{GS} = 2.5V | 100mA |

Features and Benefits

- Low On-Resistance
- Low Input Capacitance
- Fast Switching Speed
- ESD Protected

Description and Applications

This MOSFET is designed to meet the stringent requirements of automotive applications. It is qualified to AEC-Q101, supported by a PPAP and is ideal for use in:

- Motor Control
- DC-DC Converters
- Backlighting

Mechanical Data

- Case: SOT363
- Case Material: Molded Plastic, "Green" Molding Compound. UL Flammability Classification Rating 94V-0
- Moisture Sensitivity: Level 1 per J-STD-020
- Terminal Connections Indicator: See Diagram
- Terminals: Finish — Matte Tin Annealed over Alloy 42 Leadframe. Solderable per MIL-STD-202, Method 208 
- Weight: 0.006 grams (Approximate)

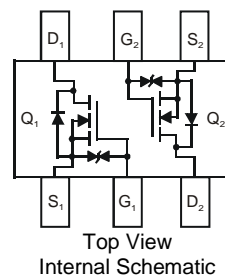

Maximum Ratings (@ $T_A = +25^\circ\text{C}$, unless otherwise specified.)

| Characteristic | | | Symbol | Value | Unit |
|--|--------------|---------------------------|-----------|----------|------|
| Drain-Source Voltage | | | V_{DSS} | 30 | V |
| Gate-Source Voltage | | | V_{GSS} | ± 20 | V |
| Continuous Drain Current (Note 6) $V_{GS} = 4.5\text{V}$ | Steady State | $T_A = +25^\circ\text{C}$ | I_D | 250 | mA |
| | | $T_A = +70^\circ\text{C}$ | | 200 | |
| Maximum Continuous Body Diode Forward Current (Note 6) | | | I_S | 0.5 | A |
| Pulsed Drain Current (10 μs Pulse, Duty Cycle=1%) | | | I_{DM} | 0.8 | A |

Thermal Characteristics (@ $T_A = +25^\circ\text{C}$, unless otherwise specified.)

| Characteristic | | Symbol | Value | Unit |
|--|---------------------------|-----------------|-------------|--------------------|
| Total Power Dissipation (Note 6) | $T_A = +25^\circ\text{C}$ | P_D | 0.35 | W |
| | $T_A = +70^\circ\text{C}$ | | 0.22 | |
| Thermal Resistance, Junction to Ambient (Note 6) | Steady State | $R_{\theta JA}$ | 360 | $^\circ\text{C/W}$ |
| Thermal Resistance, Junction to Case | | $R_{\theta JC}$ | 126 | |
| Operating and Storage Temperature Range | | T_J, T_{STG} | -55 to +150 | $^\circ\text{C}$ |

Electrical Characteristics (@ $T_A = +25^\circ\text{C}$, unless otherwise specified.)

| Characteristic | Symbol | Min | Typ | Max | Unit | Test Condition |
|--|--------------|-----|------|----------|---------------|--|
| OFF CHARACTERISTICS (Note 7) | | | | | | |
| Drain-Source Breakdown Voltage | BV_{DSS} | 30 | — | — | V | $V_{GS} = 0\text{V}, I_D = 1\text{mA}$ |
| Zero Gate Voltage Drain Current | I_{DSS} | — | — | 1 | μA | $V_{DS} = 30\text{V}, V_{GS} = 0\text{V}$ |
| Gate-Source Leakage | I_{GSS} | — | — | ± 10 | μA | $V_{GS} = \pm 20\text{V}, V_{DS} = 0\text{V}$ |
| ON CHARACTERISTICS (Note 7) | | | | | | |
| Gate Threshold Voltage | $V_{GS(TH)}$ | 0.8 | — | 1.5 | V | $V_{DS} = 3\text{V}, I_D = 100\mu\text{A}$ |
| Static Drain-Source On-Resistance | $R_{DS(ON)}$ | — | — | 2.4 | Ω | $V_{GS} = 10\text{V}, I_D = 250\text{mA}$ |
| | | — | — | 3.0 | | $V_{GS} = 4.5\text{V}, I_D = 250\text{mA}$ |
| | | — | — | 5.0 | | $V_{GS} = 4.0\text{V}, I_D = 10\text{mA}$ |
| | | — | — | 7.0 | | $V_{GS} = 2.5\text{V}, I_D = 5\text{mA}$ |
| Diode Forward Voltage | V_{SD} | — | — | 1.2 | V | $V_{GS} = 0\text{V}, I_S = 115\text{mA}$ |
| DYNAMIC CHARACTERISTICS (Note 8) | | | | | | |
| Input Capacitance | C_{iss} | — | 48 | — | pF | $V_{DS} = 5\text{V}, V_{GS} = 0\text{V}, f = 1.0\text{MHz}$ |
| Output Capacitance | C_{oss} | — | 11 | — | pF | |
| Reverse Transfer Capacitance | C_{rss} | — | 8 | — | pF | |
| Gate Resistance | R_g | — | 57 | — | Ω | $f = 1\text{MHz}, V_{GS} = 0\text{V}, V_{DS} = 0\text{V}$ |
| Total Gate Charge ($V_{GS} = 4.5\text{V}$) | Q_g | — | 0.55 | — | nC | $V_{DS} = 10\text{V}, I_D = 250\text{mA}$ |
| Total Gate Charge ($V_{GS} = 10\text{V}$) | Q_g | — | 1.23 | — | nC | |
| Gate-Source Charge | Q_{gs} | — | 0.14 | — | nC | |
| Gate-Drain Charge | Q_{gd} | — | 0.14 | — | nC | |
| Turn-On Delay Time | $t_{D(ON)}$ | — | 2.9 | — | ns | $V_{DD} = 30\text{V}, V_{GS} = 10\text{V}, R_G = 25\Omega, I_D = 200\text{mA}$ |
| Turn-On Rise Time | t_R | — | 2.6 | — | ns | |
| Turn-Off Delay Time | $t_{D(OFF)}$ | — | 18.2 | — | ns | |
| Turn-Off Fall Time | t_F | — | 13.6 | — | ns | |

- Notes:
- Device mounted on 1" x 1" FR-4 PCB with high coverage 2oz. Copper, single sided.
 - Short duration pulse test used to minimize self-heating effect.
 - Guaranteed by design. Not subject to product testing.

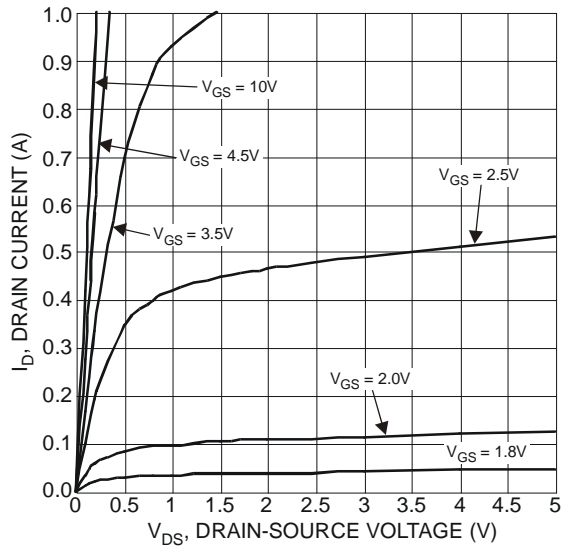

Figure 1 Typical Output Characteristics

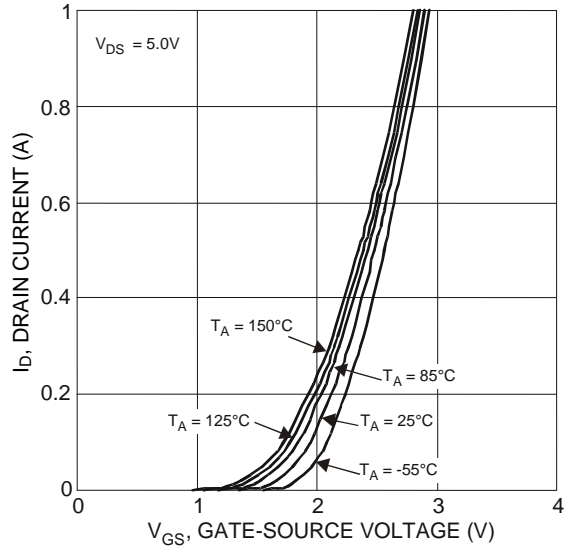

Figure 2 Typical Transfer Characteristics

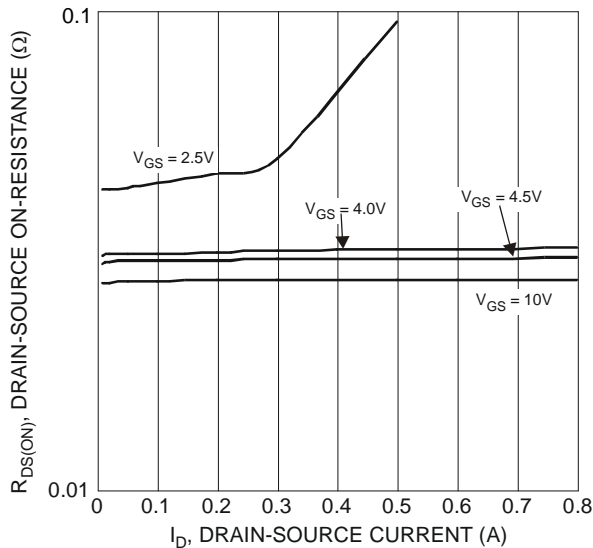

Figure 3 Typical On-Resistance vs. Drain Current and Gate Voltage

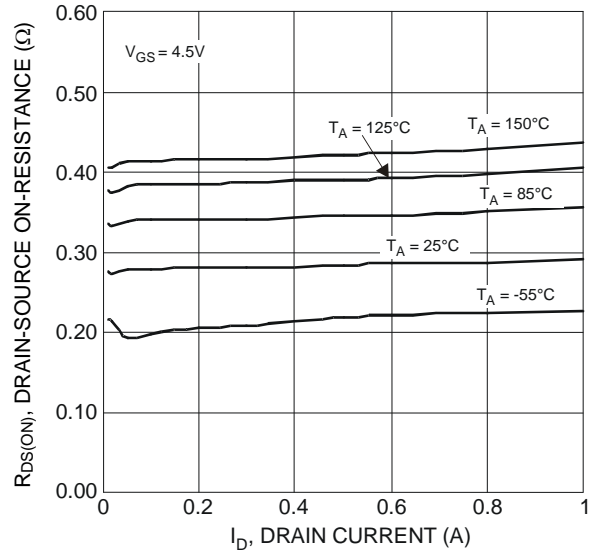

Figure 4 Typical On-Resistance vs. Drain Current and Temperature

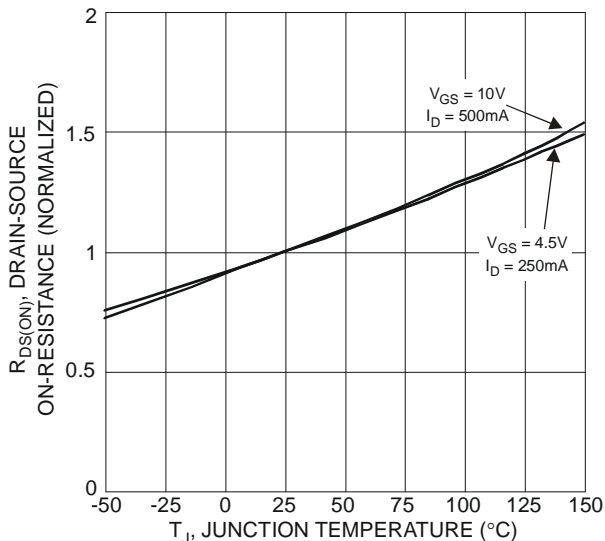

Figure 5 On-Resistance Variation with Temperature

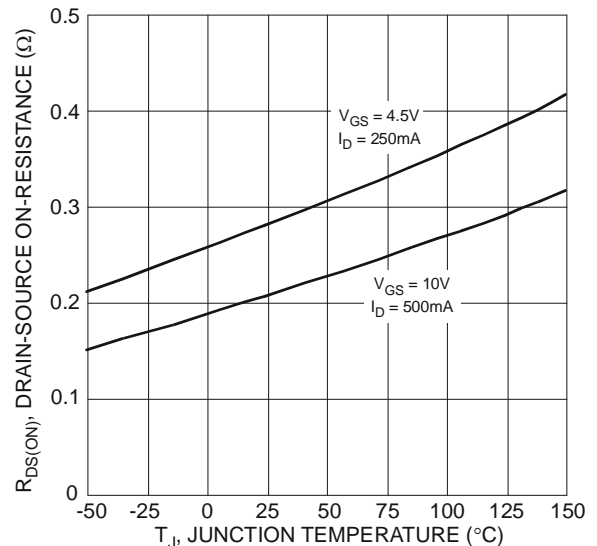

Figure 6 On-Resistance Variation with Temperature

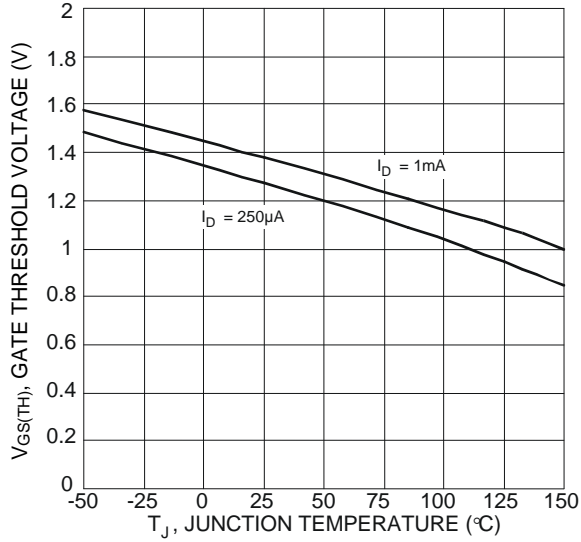

Figure 7 Gate Threshold Variation vs. Junction Temperature

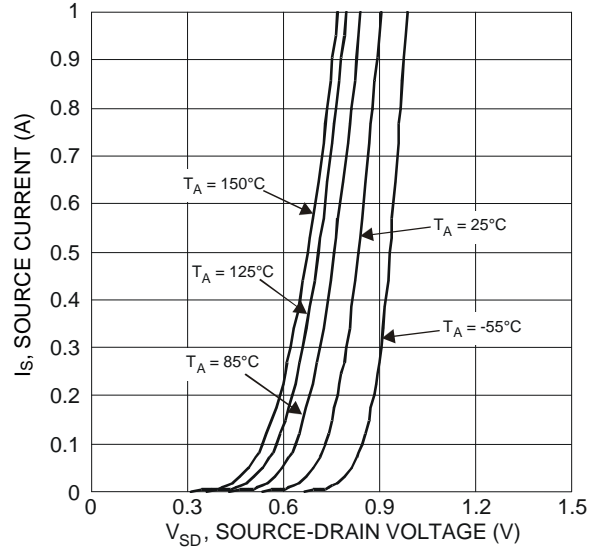

Figure 8 Diode Forward Voltage vs. Current

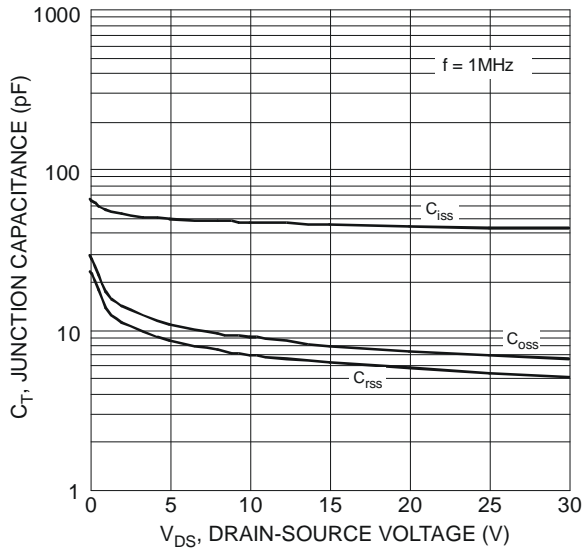

Figure 9 Typical Junction Capacitance

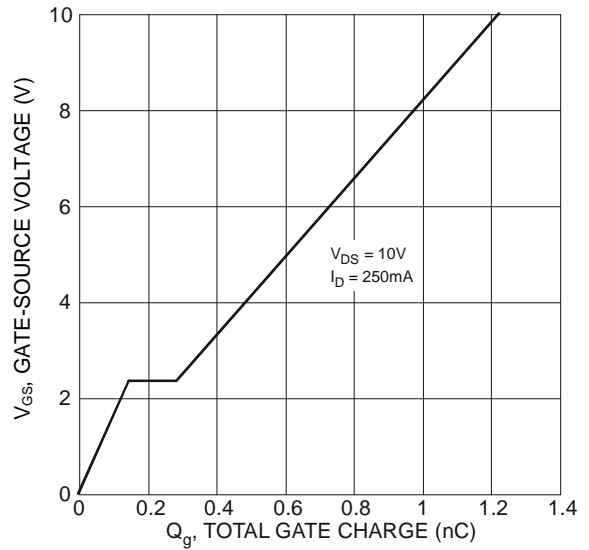

Figure 10 Gate Charge

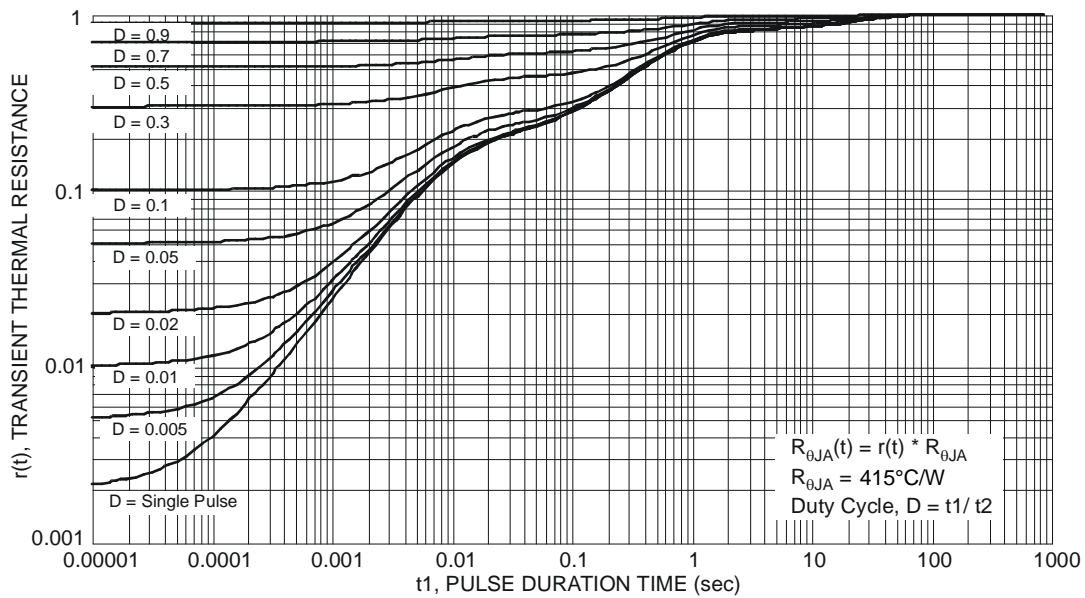
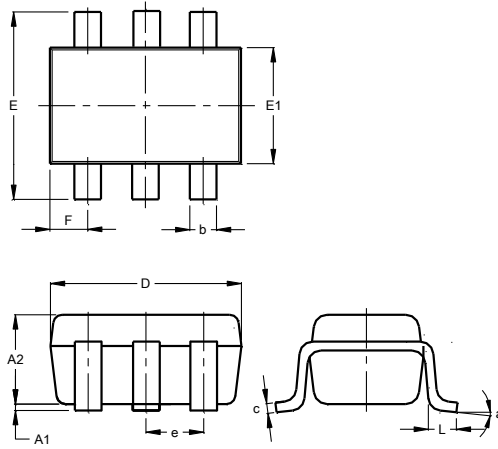

Figure 11 Transient Thermal Resistance

Package Outline Dimensions

SOT363



| SOT363 | | | |
|----------------------|-----------|------|-------|
| Dim | Min | Max | Typ |
| A1 | 0.00 | 0.10 | 0.05 |
| A2 | 0.90 | 1.00 | 0.95 |
| b | 0.10 | 0.30 | 0.25 |
| c | 0.10 | 0.22 | 0.11 |
| D | 1.80 | 2.20 | 2.15 |
| E | 2.00 | 2.20 | 2.10 |
| E1 | 1.15 | 1.35 | 1.30 |
| e | 0.650 BSC | | |
| F | 0.40 | 0.45 | 0.425 |
| L | 0.25 | 0.40 | 0.30 |
| a | 0° | 8° | -- |
| All Dimensions in mm | | | |

Suggested Pad Layout

SOT363

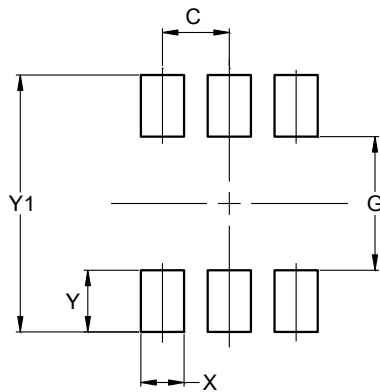

| Dimensions | Value (in mm) |
|------------|---------------|
| C | 0.650 |
| G | 1.300 |
| X | 0.420 |
| Y | 0.600 |
| Y1 | 2.500 |