



YOUSHANG SEMICONDUCTOR

设计研发新型功率器件

各类小信号开关

中低压及高压大电流等场效应管

0755-83047638

ysbdt@szyoushang.cn

www.szyoushang.cn



企业微信二维码



企业QQ二维码

Product Summary

| BV _{DSS} | R _{DS(ON)} Max | I _D Max (A) T _A = +25°C |
|-------------------|--------------------------------|--|
| -40V | 25mΩ @ V _{GS} = -10V | -7.2A |
| | 45mΩ @ V _{GS} = -4.5V | -5.3A |

Features and Benefits

- 100% Unclamped Inductive Switch (UIS) Test in Production
- Low R_{DS(ON)} – Minimizes Conduction Losses
- Fast Switching Speed – Minimizes Switching Losses

Description and Applications

This MOSFET is designed to meet the stringent requirements of automotive applications. It is qualified to AEC-Q101, supported by a PPAP and is ideal for use in:

- Motor controls
- Backlighting
- DC-DC converters
- Printer equipment

Mechanical Data

- Package: SO-8
- Package Material: Molded Plastic, "Green" Molding Compound. UL Flammability Classification Rating 94V-0
- Moisture Sensitivity: Level 1 per J-STD-020
- Terminals: Finish – Matte Tin Annealed over Copper Leadframe. Solderable per MIL-STD-202, Method 208 ^③
- Weight: 0.074 grams (Approximate)

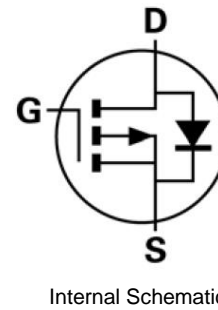
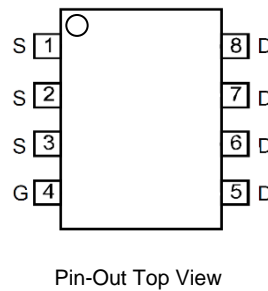

Maximum Ratings (@T_A = +25°C, unless otherwise specified.)

| Characteristic | | | Symbol | Value | Unit |
|---|--------------|------------------------|------------------|-------|------|
| Drain-Source Voltage | | | V _{DSS} | -40 | V |
| Gate-Source Voltage | | | V _{GSS} | ±20 | V |
| Continuous Drain Current (Note 6) V _{GS} = -10V | Steady State | T _A = +25°C | I _D | -7.2 | A |
| | | T _A = +70°C | | -5.7 | |
| Maximum Body Diode Forward Current (Note 6) | | | I _S | -7.2 | A |
| Pulsed Drain Current (10μs Pulse, Duty Cycle = 1%) | | | I _{DM} | -46 | A |
| Pulsed Body Diode Forward Current (10μs Pulse, Duty Cycle = 1%) | | | I _{SM} | -46 | A |
| Avalanche Current, L = 0.3mH | | | I _{AS} | -20 | A |
| Avalanche Energy, L = 0.3mH | | | E _{AS} | 62 | mJ |

Thermal Characteristics (@T_A = +25°C, unless otherwise specified.)

| Characteristic | | | Symbol | Value | Unit |
|--|--|--------------|-----------------------------------|-------------|------|
| Total Power Dissipation (Note 5) | | | P _D | 1.5 | W |
| Thermal Resistance, Junction to Ambient (Note 5) | | Steady State | R _{θJA} | 82.7 | °C/W |
| Total Power Dissipation (Note 6) | | | P _D | 2.0 | W |
| Thermal Resistance, Junction to Ambient (Note 6) | | Steady State | R _{θJA} | 60.3 | °C/W |
| Thermal Resistance, Junction to Case | | | R _{θJC} | 8.3 | |
| Operating and Storage Temperature Range | | | T _J , T _{STG} | -55 to +150 | °C |

Electrical Characteristics (@T_A = 25°C unless otherwise specified)

| Characteristic | Symbol | Min | Typ | Max | Unit | Test Condition |
|---|---------------------|------|------|------|------|--|
| OFF CHARACTERISTICS (Note 7) | | | | | | |
| Drain-Source Breakdown Voltage | BV _{DSS} | -40 | — | — | V | V _{GS} = 0V, I _D = -250μA |
| Zero Gate Voltage Drain Current | I _{DSS} | — | — | -1.0 | μA | V _{DS} = -40V, V _{GS} = 0V |
| Gate-Source Leakage | I _{GSS} | — | — | ±100 | nA | V _{GS} = ±20V, V _{DS} = 0V |
| ON CHARACTERISTICS (Note 7) | | | | | | |
| Gate Threshold Voltage | V _{GS(TH)} | -0.8 | — | -1.8 | V | V _{DS} = V _{GS} , I _D = -250μA |
| Static Drain-Source On-Resistance | R _{DS(ON)} | — | 13.9 | 25 | mΩ | V _{GS} = -10V, I _D = -3A |
| | | — | 17.2 | 45 | | V _{GS} = -4.5V, I _D = -3A |
| Diode Forward Voltage | V _{SD} | — | -0.7 | -1.0 | V | V _{GS} = 0V, I _S = -1A |
| DYNAMIC CHARACTERISTICS (Note 8) | | | | | | |
| Input Capacitance | C _{ISS} | — | 2083 | — | pF | V _{DS} = -20V, V _{GS} = 0V f = 1.0MHz |
| Output Capacitance | C _{OSS} | — | 221 | — | | |
| Reverse Transfer Capacitance | C _{RSS} | — | 191 | — | | |
| Gate Resistance | R _G | — | 2.5 | — | Ω | V _{DS} = 0V, V _{GS} = 0V, f = 1.0MHz |
| Total Gate Charge (V _{GS} = -10V) | Q _G | — | 45 | — | nC | V _{DS} = -20V, I _D = -3A |
| Total Gate Charge (V _{GS} = -4.5V) | Q _G | — | 23.5 | — | | |
| Gate-Source Charge | Q _{GS} | — | 5 | — | | |
| Gate-Drain Charge | Q _{GD} | — | 6.7 | — | | |
| Turn-On Delay Time | t _{D(ON)} | — | 4.3 | — | ns | V _{GS} = -10V, V _{DD} = -20V, R _G = 6Ω, I _D = -3A |
| Turn-On Rise Time | t _R | — | 4.8 | — | | |
| Turn-Off Delay Time | t _{D(OFF)} | — | 71 | — | | |
| Turn-Off Fall Time | t _F | — | 24 | — | | |
| Body Diode Reverse Recovery Time | t _{RR} | — | 17.3 | — | ns | I _S = -3A, di/dt = 100A/μs |
| Body Diode Reverse Recovery Charge | Q _{RR} | — | 8.7 | — | nC | I _S = -3A, di/dt = 100A/μs |

- Notes:
- Device mounted on FR-4 substrate PC board, 2oz copper, with minimum recommended pad layout.
 - Device mounted on FR-4 substrate PC board, 2oz copper, with 1inch square copper plate.
 - Short duration pulse test used to minimize self-heating effect.
 - Guaranteed by design. Not subject to product testing.

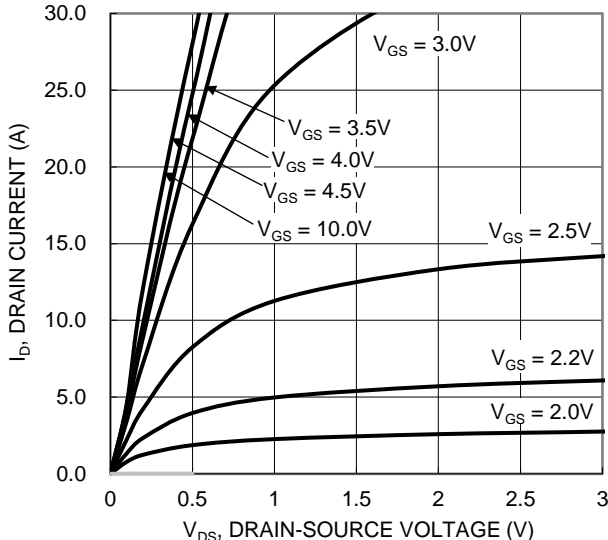

Figure 1. Typical Output Characteristic

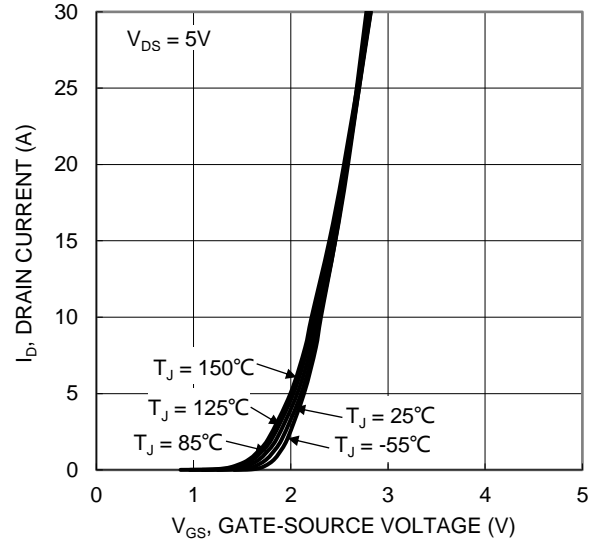

Figure 2. Typical Transfer Characteristic

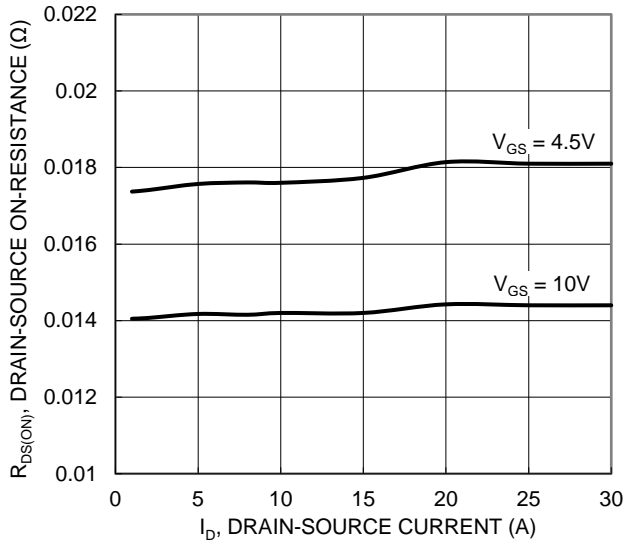

Figure 3. Typical On-Resistance vs. Drain Current and Gate Voltage

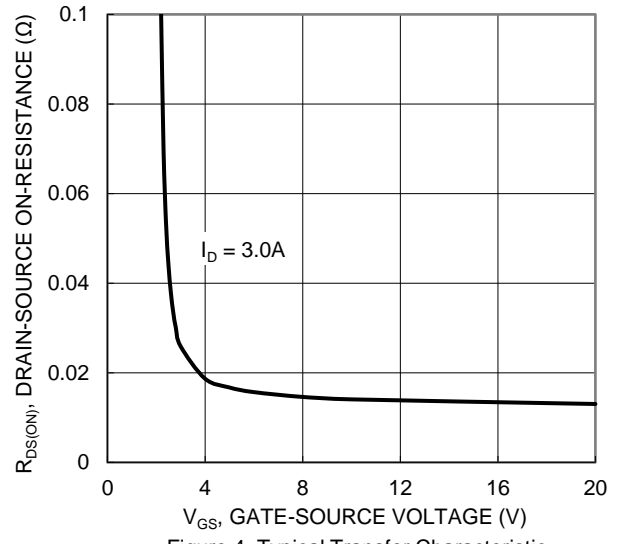

Figure 4. Typical Transfer Characteristic

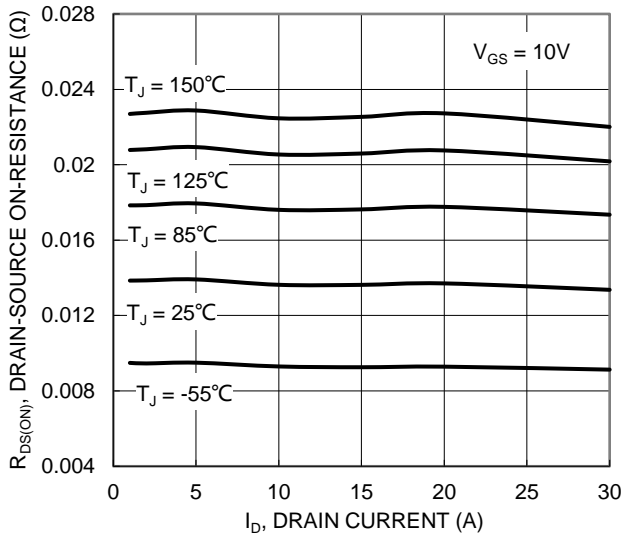

Figure 5. Typical On-Resistance vs. Drain Current and Junction Temperature

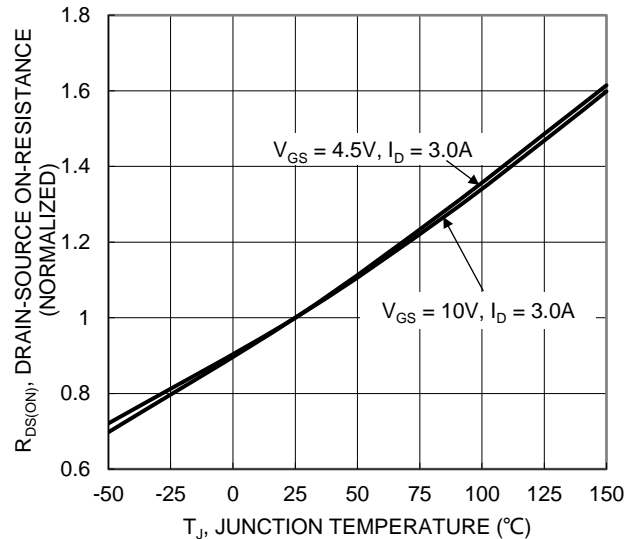

Figure 6. On-Resistance Variation with Junction Temperature

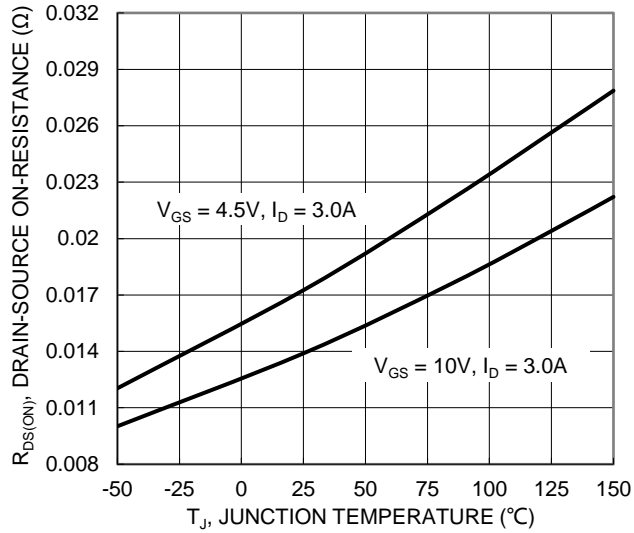

Figure 7. On-Resistance Variation with Junction Temperature

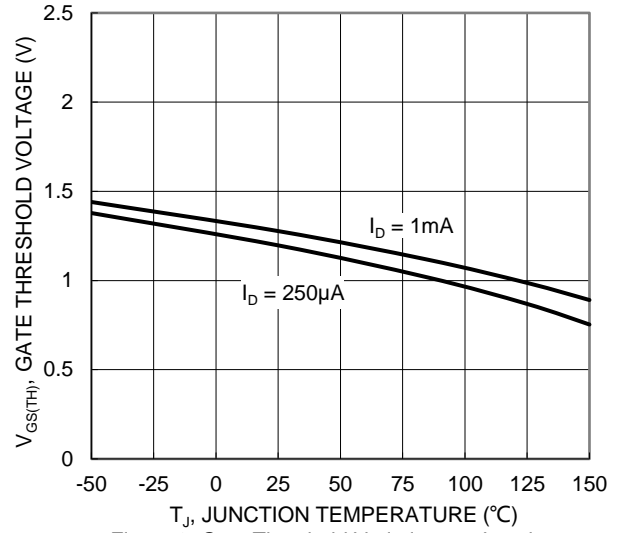

Figure 8. Gate Threshold Variation vs. Junction Temperature

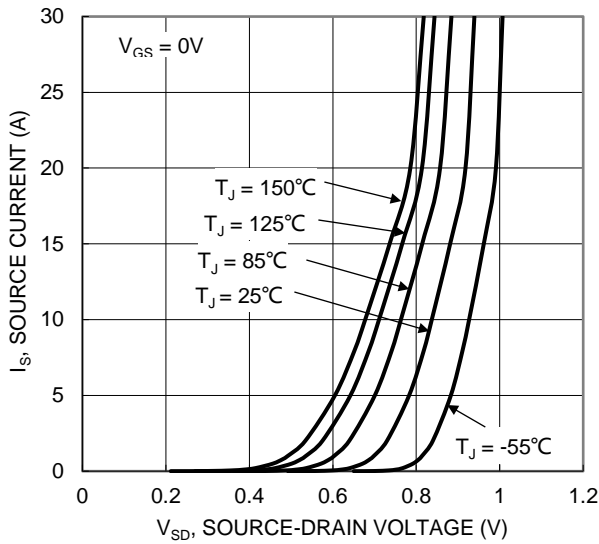

Figure 9. Diode Forward Voltage vs. Current

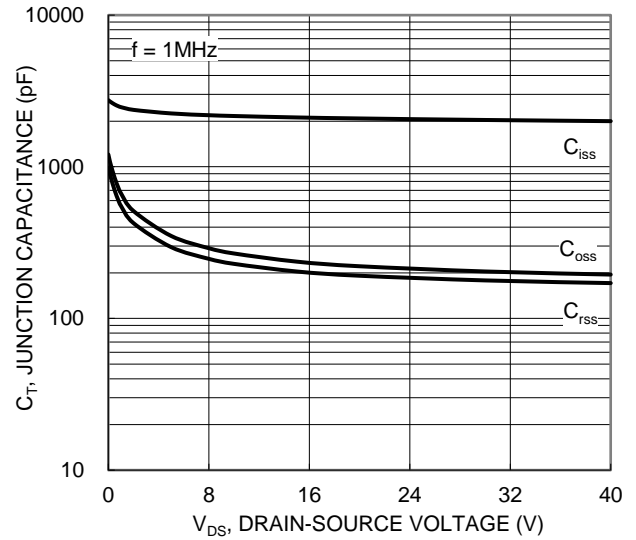

Figure 10. Typical Junction Capacitance

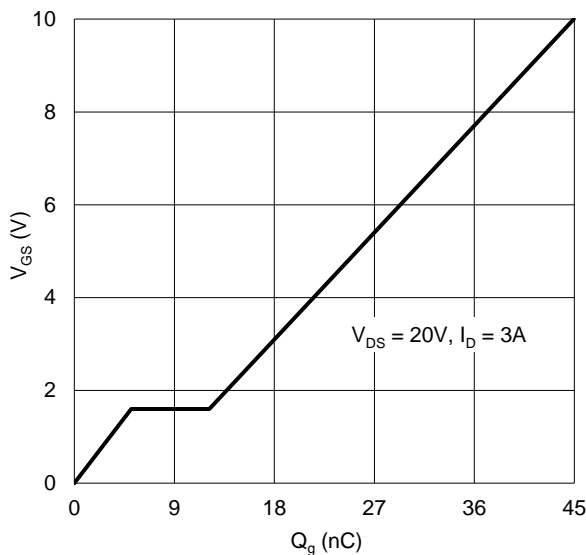

Figure 11. Gate Charge

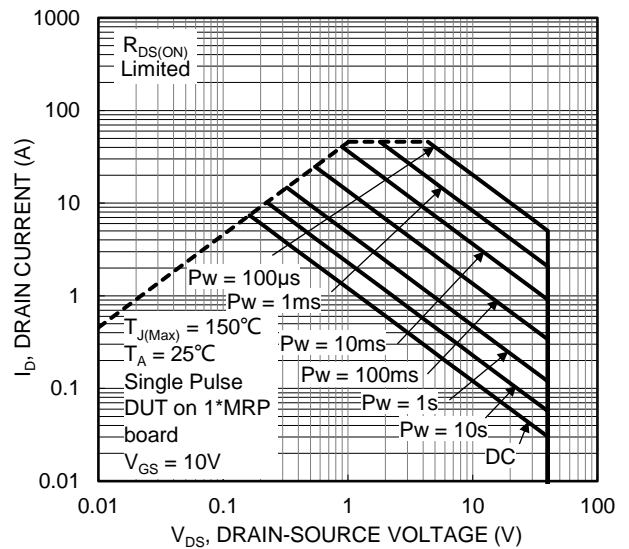

Figure 12. SOA, Safe Operation Area

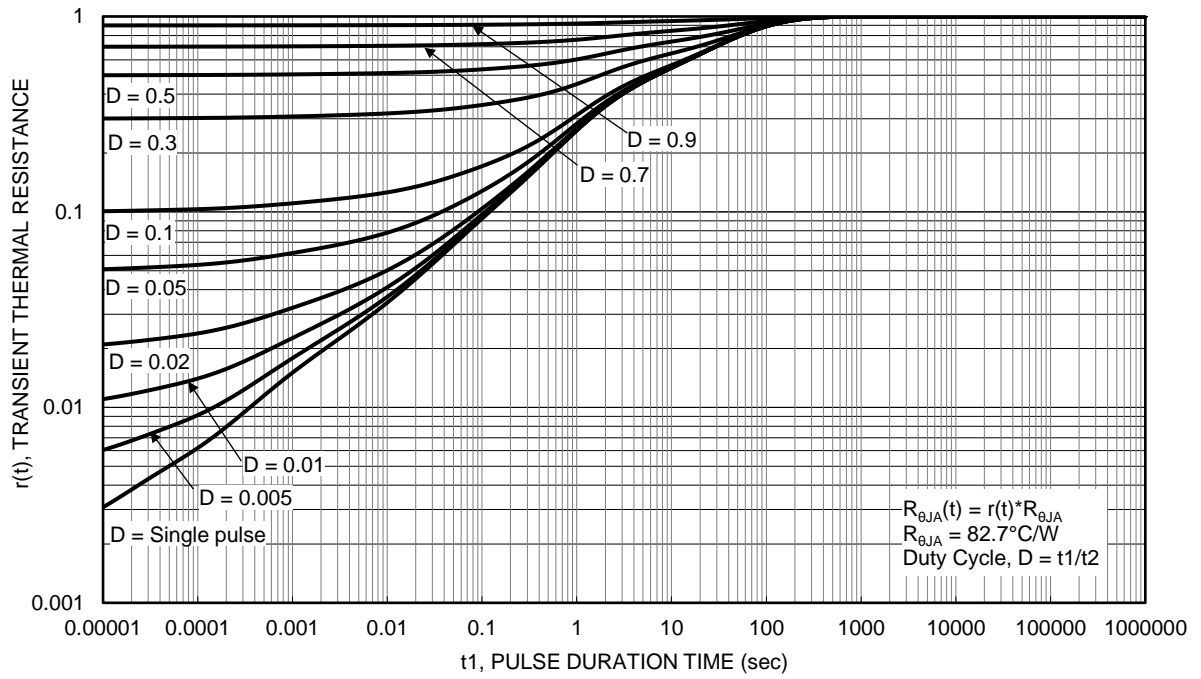
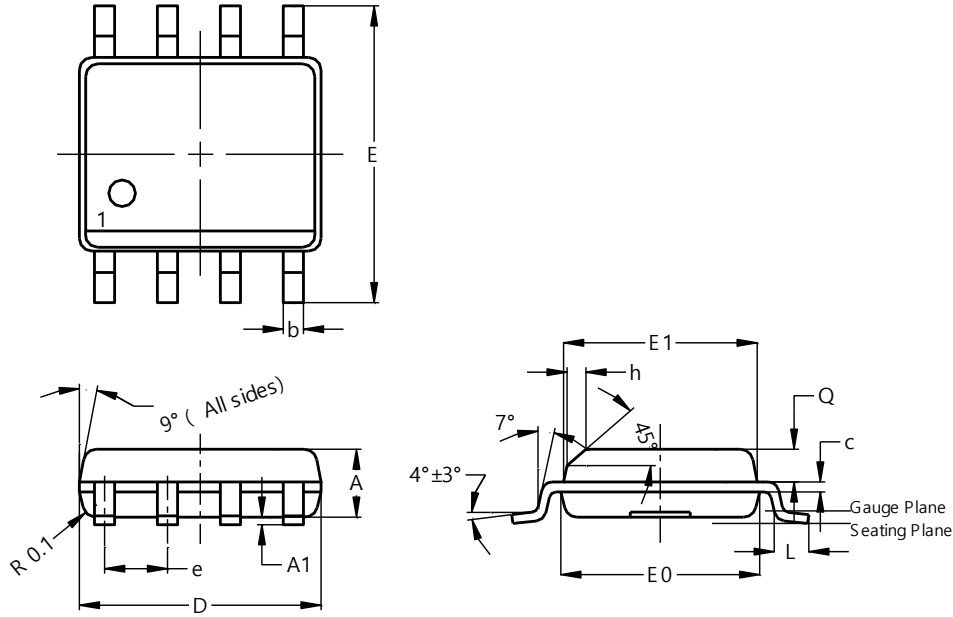

Figure 13. Transient Thermal Resistance

Package Outline Dimensions

SO-8



| SO-8 | | | |
|----------------------|------|------|------|
| Dim | Min | Max | Typ |
| A | 1.40 | 1.50 | 1.45 |
| A1 | 0.10 | 0.20 | 0.15 |
| b | 0.30 | 0.50 | 0.40 |
| c | 0.15 | 0.25 | 0.20 |
| D | 4.85 | 4.95 | 4.90 |
| E | 5.90 | 6.10 | 6.00 |
| E1 | 3.80 | 3.90 | 3.85 |
| E0 | 3.85 | 3.95 | 3.90 |
| e | -- | -- | 1.27 |
| h | -- | -- | 0.35 |
| L | 0.62 | 0.82 | 0.72 |
| Q | 0.60 | 0.70 | 0.65 |
| All Dimensions in mm | | | |

Suggested Pad Layout

SO-8

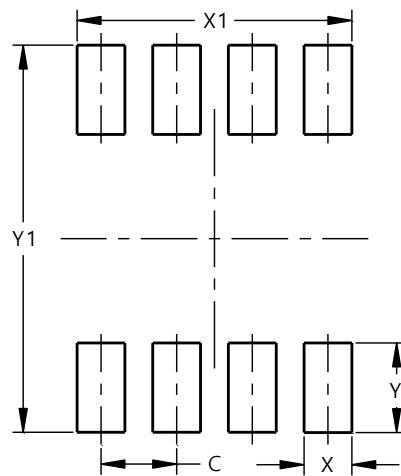

| Dimensions | Value (in mm) |
|------------|---------------|
| C | 1.27 |
| X | 0.802 |
| X1 | 4.612 |
| Y | 1.505 |
| Y1 | 6.50 |