



YOUSHANG SEMICONDUCTOR

设计研发新型功率器件

各类小信号开关

中低压及高压大电流等场效应管

0755-83047638

ysbdt@szyoushang.cn

www.szyoushang.cn



企业微信二维码



企业QQ二维码

Product Summary

BV_{DSS}	$R_{DS(ON)}$ Max	I_D Max $T_C = +25^\circ C$
30V	11m Ω @ $V_{GS} = 10V$	50A
	13m Ω @ $V_{GS} = 4.5V$	45A

Description and Applications

This MOSFET is designed to minimize the on-state resistance ($R_{DS(ON)}$) and yet maintain superior switching performance, making it ideal for high efficiency power management applications.

- Backlighting
- Power Management Functions
- DC-DC Converters

Features and Benefits

- Low $R_{DS(ON)}$ – Ensures On State Losses Are Minimized
- 100% Unclamped Inductive Switching (Test in Production) – Ensures More Reliable
- Small Form Factor Thermally Efficient Package Enables Higher Density End Products
- Occupies Just 33% of The Board Area Occupied by SO-8 Enabling Smaller End Product
- Wettable Flank for Improved Optical Inspection

Mechanical Data

- Case: PowerDI[®]3333-8 (SWP) (Type UX)
- Case Material: Molded Plastic, "Green" Molding Compound. UL Flammability Classification Rating 94V-0
- Moisture Sensitivity: Level 1 per J-STD-020
- Terminal Connections Indicator: See Diagram
- Terminals: Finish — Matte Tin Annealed over Copper Leadframe. Solderable per MIL-STD-202, Method 208 
- Weight: 0.03 grams (Approximate)

PowerDI3333-8 (SWP) (Type UX)

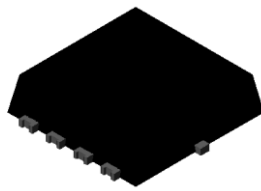

Top View

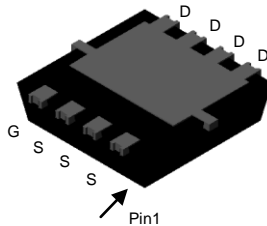

Bottom View

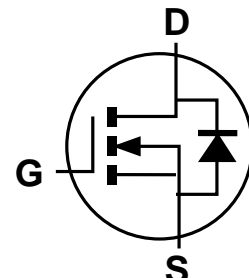

Equivalent Circuit

Maximum Ratings (@ $T_A = +25^\circ\text{C}$, unless otherwise specified.)

Characteristic	Symbol	Value	Unit	
Drain-Source Voltage	V_{DSS}	30	V	
Gate-Source Voltage	V_{GSS}	± 20	V	
Continuous Drain Current $V_{GS} = 10\text{V}$	$T_A = +25^\circ\text{C}$ $T_A = +70^\circ\text{C}$	I_D	12	A
		I_D	10	A
	$T_C = +25^\circ\text{C}$ $T_C = +70^\circ\text{C}$	I_D	50	A
		I_D	37	A
Maximum Continuous Body Diode Forward Current (Note 6)	I_S	3	A	
Pulsed Drain Current (10 μs Pulse, Duty Cycle = 1%)	I_{DM}	90	A	
Pulsed Body Diode Forward Current (10 μs Pulse, Duty Cycle = 1%)	I_{SM}	90	A	
Avalanche Current, $L = 0.1\text{mH}$	I_{AS}	19	A	
Avalanche Energy, $L = 0.1\text{mH}$	E_{AS}	19	mJ	

Thermal Characteristics (@ $T_A = +25^\circ\text{C}$, unless otherwise specified.)

Characteristic	Symbol	Value	Unit
Total Power Dissipation (Note 6)	P_D	2.3	W
Thermal Resistance, Junction to Ambient (Note 6)	$R_{\theta JA}$	55	$^\circ\text{C/W}$
Total Power Dissipation (Note 9)	P_D	35.7	W
Thermal Resistance, Junction to Case (Note 9)	$R_{\theta JC}$	3.5	$^\circ\text{C/W}$
Operating and Storage Temperature Range	T_J, T_{STG}	-55 to +150	$^\circ\text{C}$

Electrical Characteristics (@ $T_A = +25^\circ\text{C}$, unless otherwise specified.)

Characteristic	Symbol	Min	Typ	Max	Unit	Test Condition
OFF CHARACTERISTICS (Note 7)						
Drain-Source Breakdown Voltage	BV_{DSS}	30	-	-	V	$V_{GS} = 0\text{V}, I_D = 250\mu\text{A}$
Zero Gate Voltage Drain Current	I_{DSS}	-	-	1	μA	$V_{DS} = 24\text{V}, V_{GS} = 0\text{V}$
Gate-Source Leakage	I_{GSS}	-	-	± 100	nA	$V_{GS} = \pm 16\text{V}, V_{DS} = 0\text{V}$
ON CHARACTERISTICS (Note 7)						
Gate Threshold Voltage	$V_{GS(TH)}$	1	-	3	V	$V_{DS} = V_{GS}, I_D = 250\mu\text{A}$
Static Drain-Source On-Resistance	$R_{DS(ON)}$	-	6.6	11	m Ω	$V_{GS} = 10\text{V}, I_D = 14.4\text{A}$
		-	10.5	13		$V_{GS} = 4.5\text{V}, I_D = 7\text{A}$
		-	13.4	20		$V_{GS} = 3.8\text{V}, I_D = 5\text{A}$
		-	0.8	1.2		$V_{GS} = 0\text{V}, I_S = 10\text{A}$
Diode Forward Voltage	V_{SD}	-	0.8	1.2	V	$V_{GS} = 0\text{V}, I_S = 10\text{A}$
DYNAMIC CHARACTERISTICS (Note 8)						
Input Capacitance	C_{ISS}	-	823	-	pF	$V_{DS} = 15\text{V}, V_{GS} = 0\text{V},$ $f = 1.0\text{MHz}$
Output Capacitance	C_{OSS}	-	352	-	pF	
Reverse Transfer Capacitance	C_{RSS}	-	52	-	pF	
Gate Resistance	R_g	-	1.2	-	Ω	$V_{DS} = 0\text{V}, V_{GS} = 0\text{V}, f = 1.0\text{MHz}$
Total Gate Charge ($V_{GS} = 4.5\text{V}$)	Q_g	-	5.8	-	nC	$V_{DS} = 15\text{V}, I_D = 14.4\text{A}$
Total Gate Charge ($V_{GS} = 10\text{V}$)	Q_g	-	12	-	nC	
Gate-Source Charge	Q_{gs}	-	1.7	-	nC	
Gate-Drain Charge	Q_{gd}	-	2.4	-	nC	
Turn-On Delay Time	$t_{D(ON)}$	-	3.2	-	ns	
Turn-On Rise Time	t_R	-	5.2	-	ns	$V_{GS} = 10\text{V}, V_{DD} = 15\text{V},$ $R_G = 1\Omega, I_D = 10\text{A}$
Turn-Off Delay Time	$t_{D(OFF)}$	-	8.9	-	ns	
Turn-Off Fall Time	t_F	-	1.5	-	ns	
Body Diode Reverse Recovery Time	t_{RR}	-	16.4	-	ns	$I_F = 10\text{A}, di/dt = 100\text{A}/\mu\text{s}$
Body Diode Reverse Recovery Charge	Q_{RR}	-	5.9	-	nC	

- Notes:
- Device mounted on FR-4 substrate PC board, 2oz copper, with thermal bias to bottom layer 1inch square copper plate.
 - Short duration pulse test used to minimize self-heating effect.
 - Guaranteed by design. Not subject to product testing.
 - Thermal resistance from junction to soldering point (on the exposed drain pad).

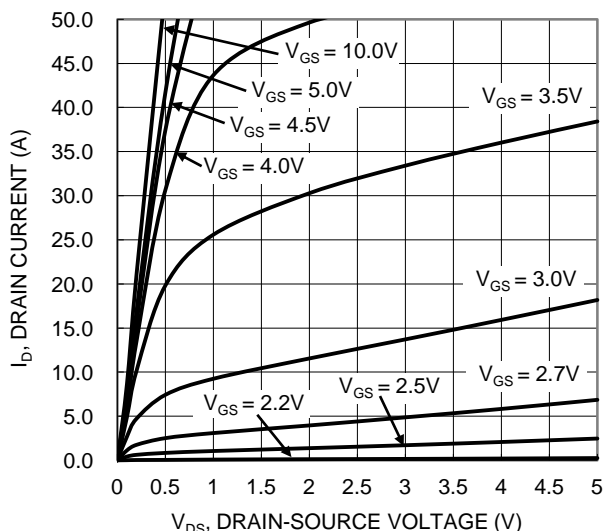

Figure 1. Typical Output Characteristic

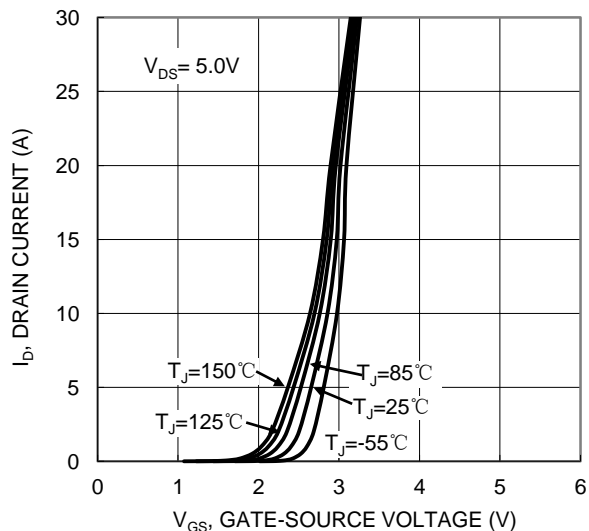

Figure 2. Typical Transfer Characteristic

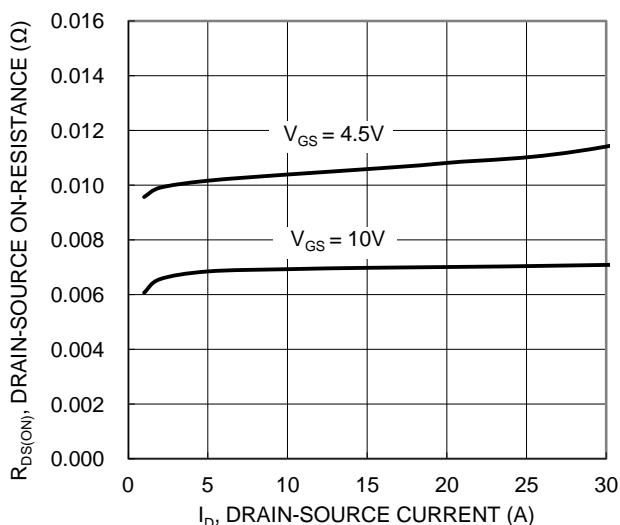

Figure 3. Typical On-Resistance vs. Drain Current and Gate Voltage

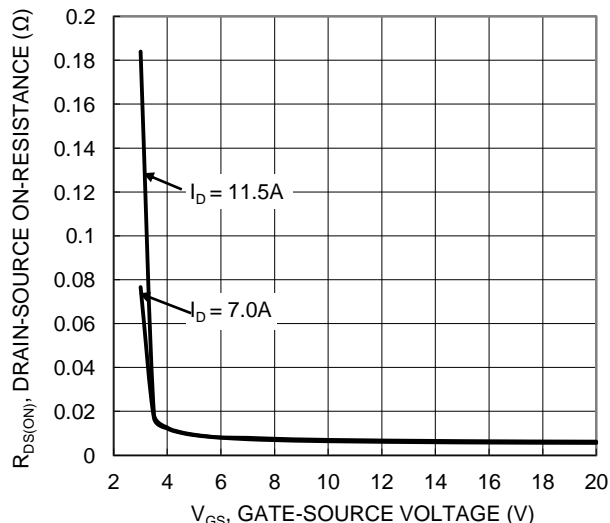

Figure 4. Typical Transfer Characteristic

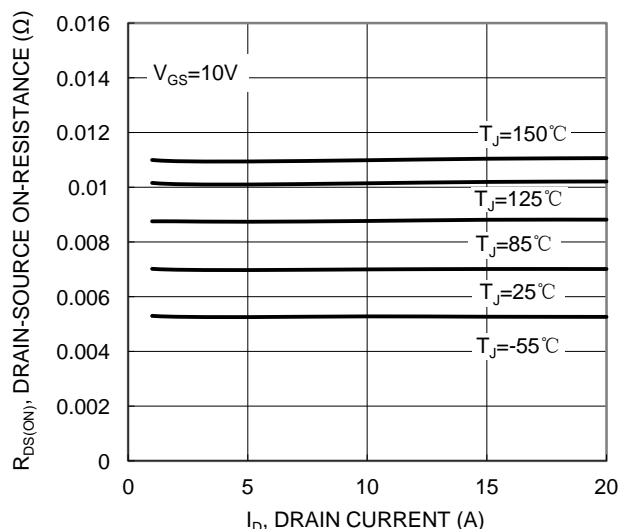

Figure 5. Typical On-Resistance vs. Drain Current and Temperature

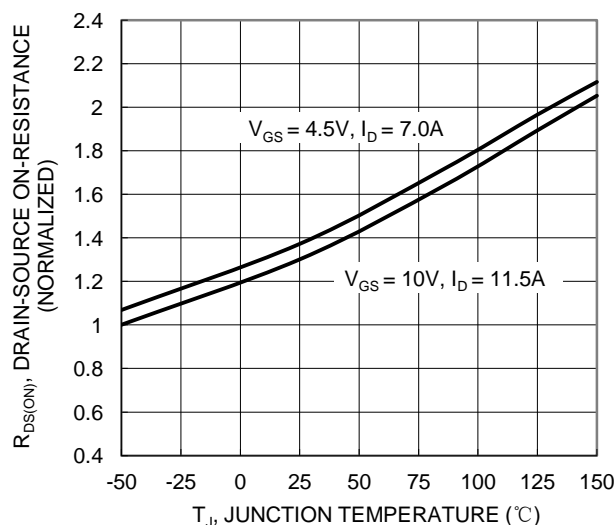

Figure 6. On-Resistance Variation with Temperature

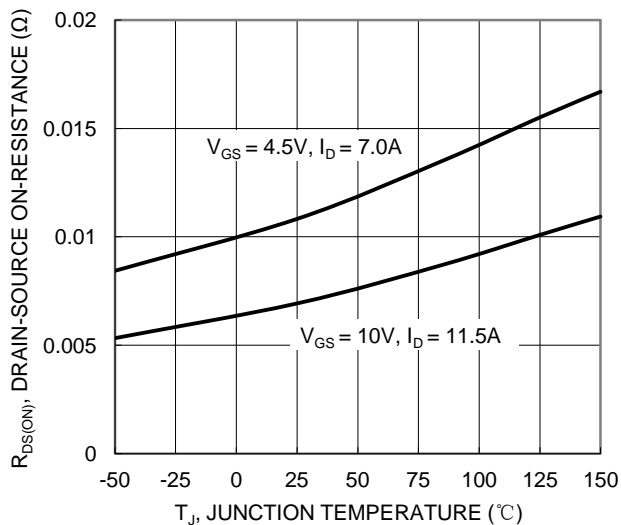

Figure 7. On-Resistance Variation with Temperature

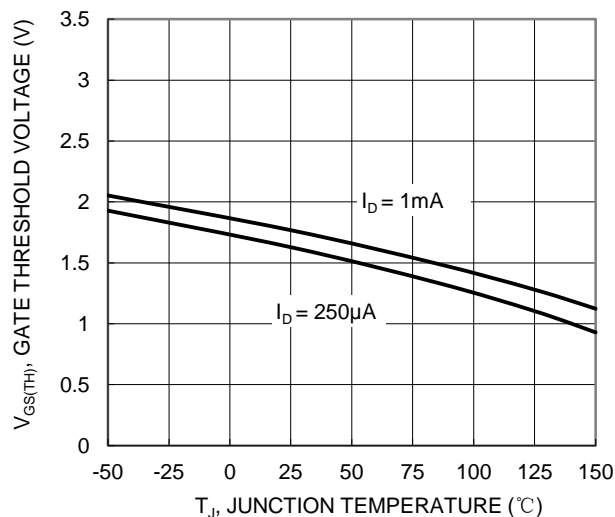

Figure 8. Gate Threshold Variation vs Junction Temperature

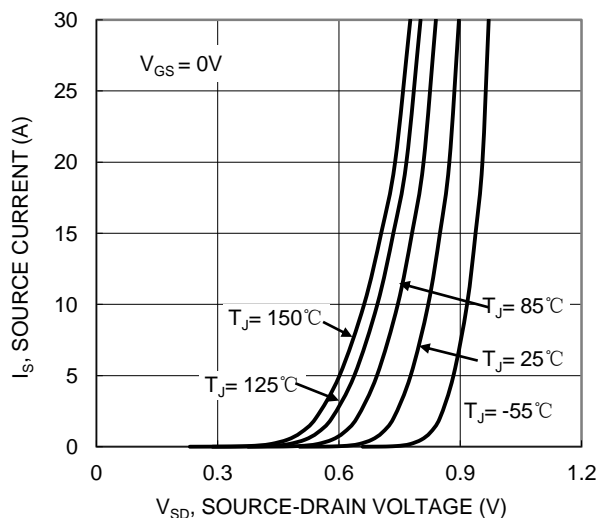

Figure 9. Diode Forward Voltage vs. Current

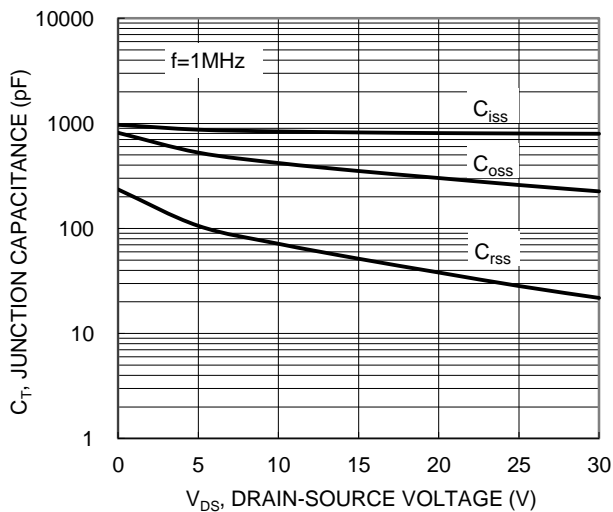

Figure 10. Typical Junction Capacitance

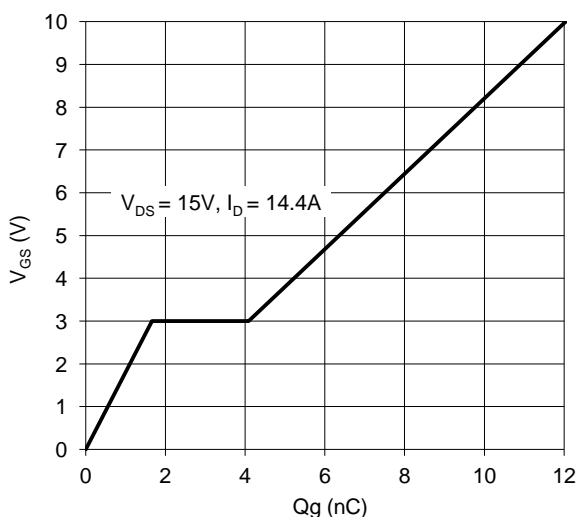

Figure 11. Gate Charge

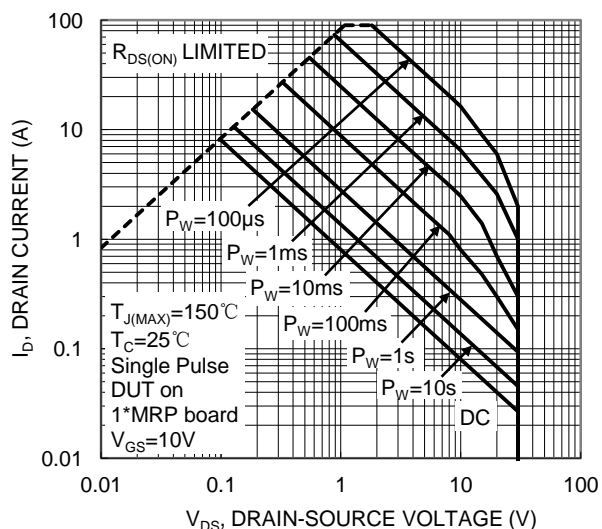

Figure 12. SOA, Safe Operation Area

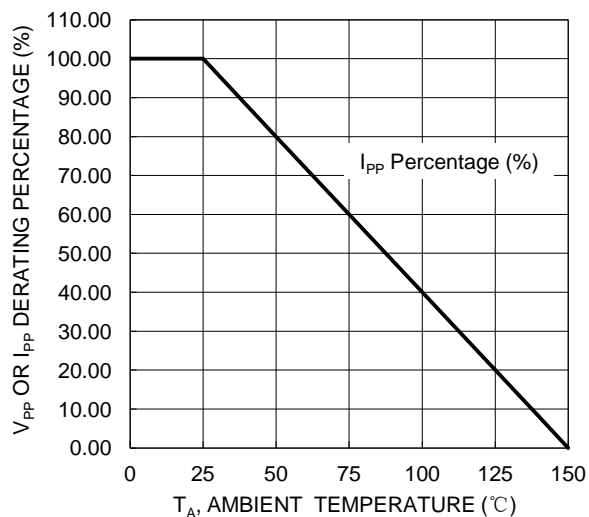

Figure 13. P_D vs. Ambient Temperature

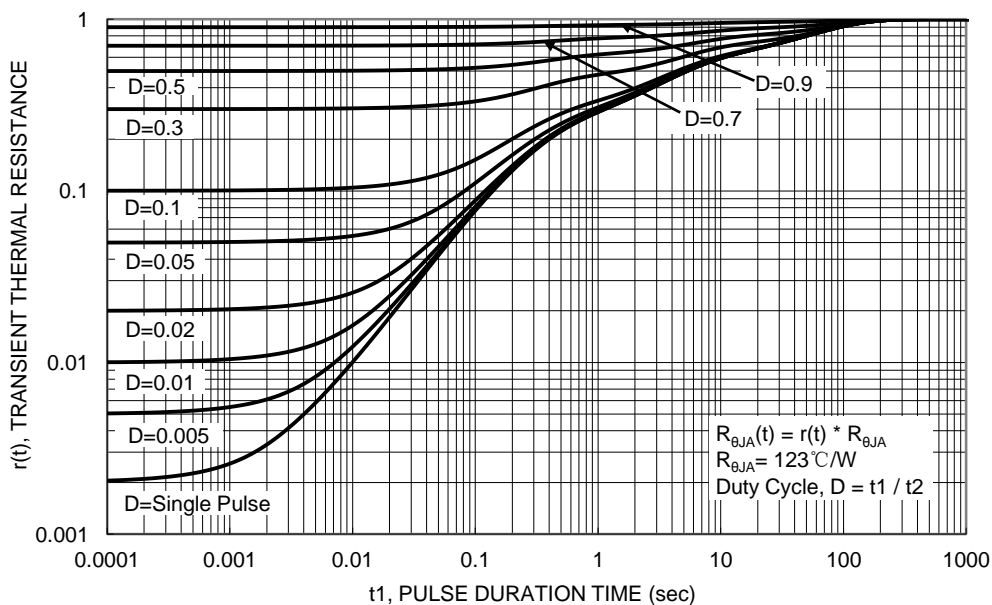
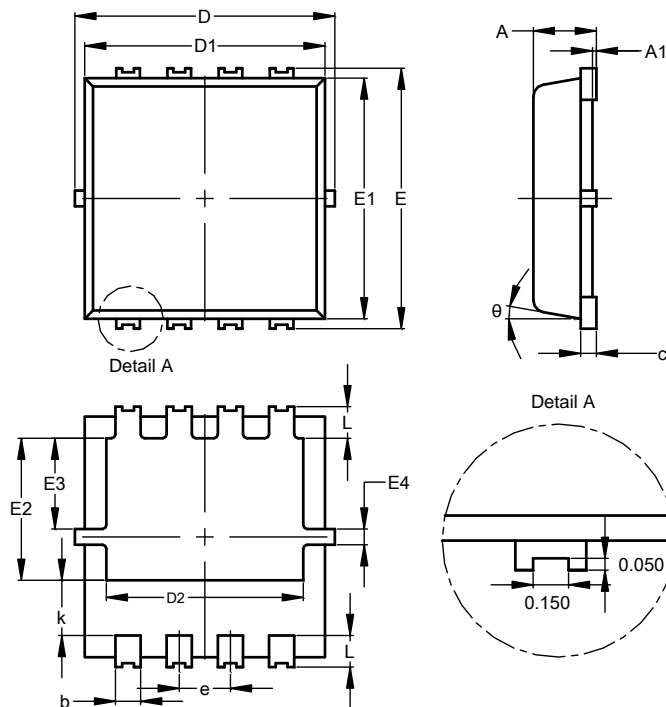

Figure 14. Transient Thermal Resistance

Package Outline Dimensions

PowerDI3333-8 (SWP) (Type UX)

PowerDI3333-8 (SWP) (Type UX)			
Dim	Min	Max	Typ
A	0.75	0.85	0.80
A1	0.00	0.05	--
b	0.25	0.40	0.32
c	0.10	0.25	0.15
D	3.20	3.40	3.30
D1	2.95	3.15	3.05
D2	2.30	2.70	2.50
E	3.20	3.40	3.30
E1	2.95	3.15	3.05
E2	1.60	2.00	1.80
E3	0.95	1.35	1.15
E4	0.10	0.30	0.20
e	--	--	0.65
k	0.50	0.90	0.70
L	0.30	0.50	0.40
θ	0°	12°	10°
All Dimensions in mm			

Suggested Pad Layout

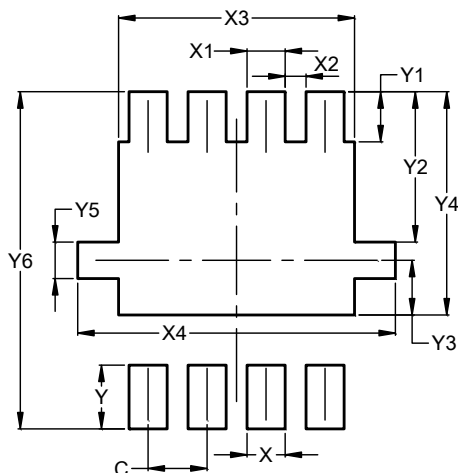
PowerDI3333-8 (SWP) (Type UX)

Dimensions	Value (in mm)
C	0.650
X	0.420
X1	0.420
X2	0.230
X3	2.600
X4	3.500
Y	0.700
Y1	0.550
Y2	1.650
Y3	0.600
Y4	2.450
Y5	0.400
Y6	3.700