



YOUSHANG SEMICONDUCTOR

设计研发新型功率器件

各类小信号开关

中低压及高压大电流等场效应管

0755-83047638

ysbdt@szyoushang.cn

www.szyoushang.cn



企业微信二维码



企业QQ二维码

Features

- Low On-Resistance
 - 38 mΩ @ $V_{GS} = 10V$
 - 64 mΩ @ $V_{GS} = 4.5V$
- Low Input Capacitance
- Fast Switching Speed

Mechanical Data

- Case: SOT-26
- Case Material: Molded Plastic, "Green" Molding Compound. UL Flammability Classification Rating 94V-0
- Moisture Sensitivity: Level 1 per J-STD-020
- Terminal Connections: See Diagram
- Terminals: Finish — Matte Tin annealed over Copper leadframe. Solderable per MIL-STD-202, Method 208
- Marking Information: See Page 4
- Ordering Information: See Page 4
- Weight: 0.015 grams (approximate)

SOT-26

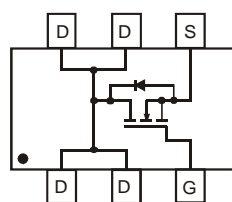

TOP VIEW

 TOP VIEW
 Internal Schematic

Maximum Ratings @ $T_A = 25^\circ C$ unless otherwise specified

Characteristic	Symbol	Value	Units
Drain-Source Voltage	V_{DSS}	30	V
Gate-Source Voltage	V_{GSS}	± 20	V
Drain Current (Note 1)	I_D	4.0	A
Pulsed Drain Current (Note 1)	I_{DM}	16	A

Thermal Characteristics

Characteristic	Symbol	Value	Units
Total Power Dissipation (Note 1)	P_D	900	mW
Thermal Resistance, Junction to Ambient	$R_{\theta JA}$	139	$^\circ C/W$
Operating and Storage Temperature Range	T_J, T_{STG}	-55 to +150	$^\circ C$

Notes: 1. Device mounted on FR-4 PCB, minimum recommended pad layout on 2oz. Copper pads.

Electrical Characteristics @ $T_A = 25^\circ\text{C}$ unless otherwise specified

Characteristic	Symbol	Min	Typ	Max	Unit	Test Condition
OFF CHARACTERISTICS (Note 4)						
Drain-Source Breakdown Voltage	BV_{DSS}	30	—	—	V	$V_{GS} = 0V, I_D = 250\mu A$
Zero Gate Voltage Drain Current	I_{DSS}	—	—	800	nA	$V_{DS} = 30V, V_{GS} = 0V$
Gate-Source Leakage	I_{GSS}	—	—	± 80 ± 800	nA	$V_{GS} = \pm 12V, V_{DS} = 0V$ $V_{GS} = \pm 20V, V_{DS} = 0V$
ON CHARACTERISTICS (Note 4)						
Gate Threshold Voltage	$V_{GS(th)}$	1.2	—	2.2	V	$V_{DS} = V_{GS}, I_D = 250\mu A$
Static Drain-Source On-Resistance	$R_{DS(on)}$	—	28 50 64	38 64	$m\Omega$	$V_{GS} = 10V, I_D = 6A$ $V_{GS} = 4.5V, I_D = 5A$
Forward Transfer Admittance	$ Y_{fs} $	—	5.2	—	S	$V_{DS} = 5V, I_D = 3.1A$
Diode Forward Voltage (Note 4)	V_{SD}	—	0.78	1.16	V	$V_{GS} = 0V, I_S = 2A$
DYNAMIC CHARACTERISTICS						
Input Capacitance	C_{iss}	—	424	—	pF	$V_{DS} = 5V, V_{GS} = 0V, f = 1.0\text{MHz}$
Output Capacitance	C_{oss}	—	115	—	pF	
Reverse Transfer Capacitance	C_{rss}	—	81	—	pF	
Gate Resistance	R_G	—	1.3	—	Ω	$V_{GS} = 0V, V_{DS} = 0V, f = 1\text{MHz}$
SWITCHING CHARACTERISTICS						
Total Gate Charge	Q_g	—	4.3 8.6	—	nC	$V_{DS} = 10V, V_{GS} = 4.5V, I_D = 10A$ $V_{DS} = 10V, V_{GS} = 10V, I_D = 10A$
Gate-Source Charge	Q_{gs}	—	1.2	—		$V_{DS} = 10V, V_{GS} = 10V, I_D = 10A$
Gate-Drain Charge	Q_{gd}	—	2.5	—		$V_{DS} = 10V, V_{GS} = 10V, I_D = 10A$

Notes: 4. Short duration pulse test used to minimize self-heating effect.

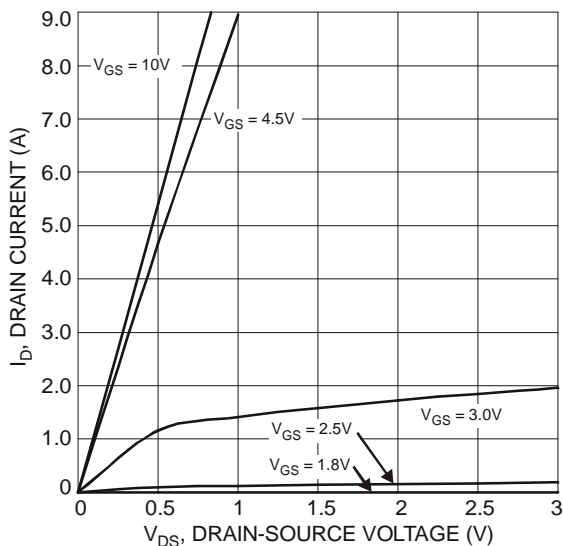

Fig. 1 Typical Output Characteristics

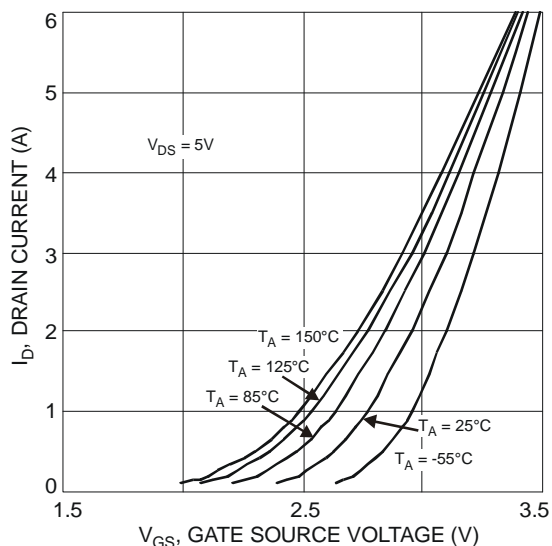

Fig. 2 Typical Transfer Characteristics

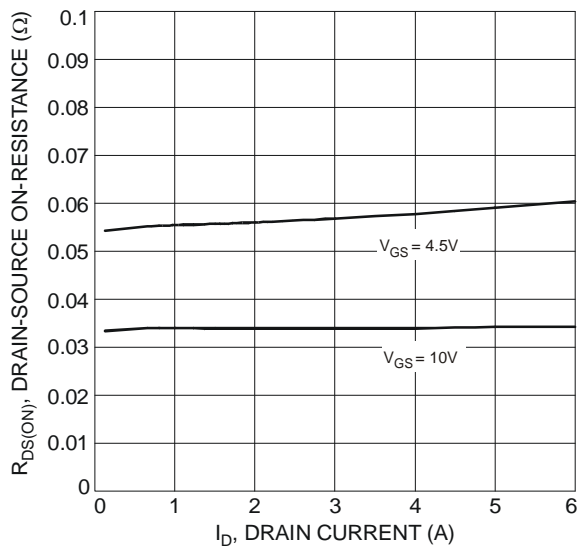

Fig. 3 Typical On-Resistance vs. Drain Current and Gate Voltage

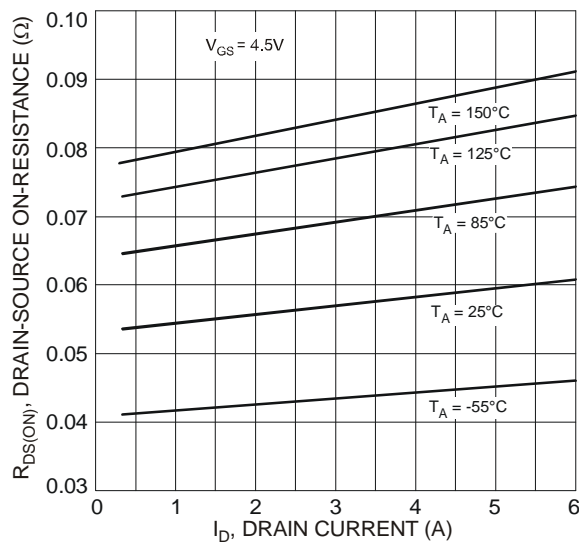

Fig. 4 Typical Drain-Source On-Resistance vs. Drain Current and Temperature

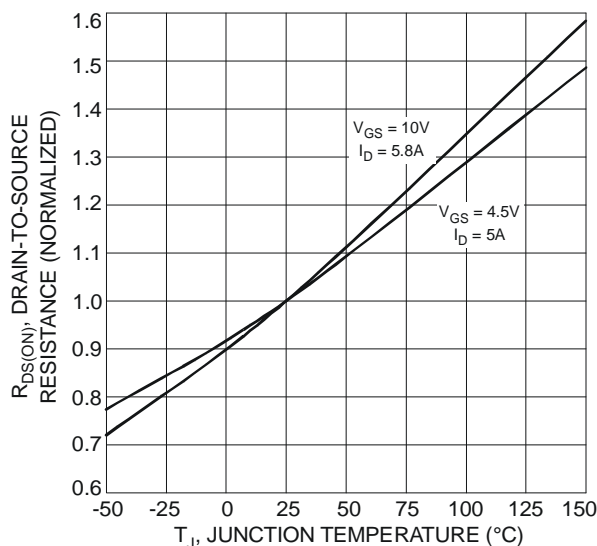

Fig. 5 On-Resistance Variation with Temperature

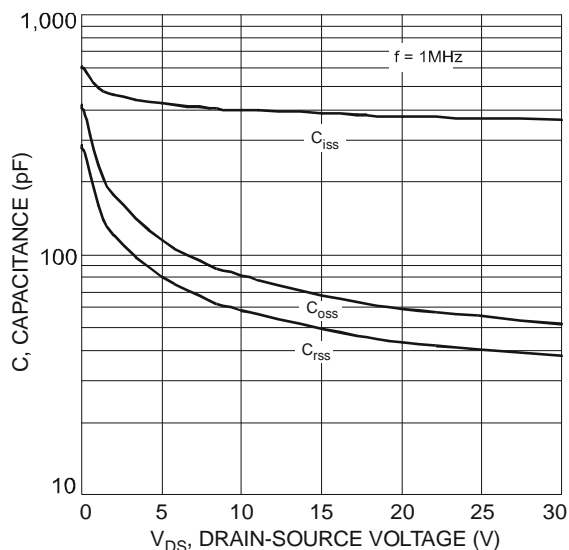

Fig. 6 Typical Capacitance

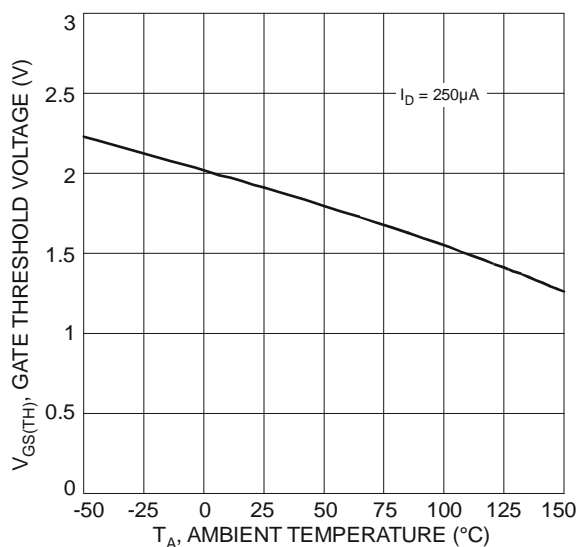

Fig. 7 Gate Threshold Variation vs. Ambient Temperature

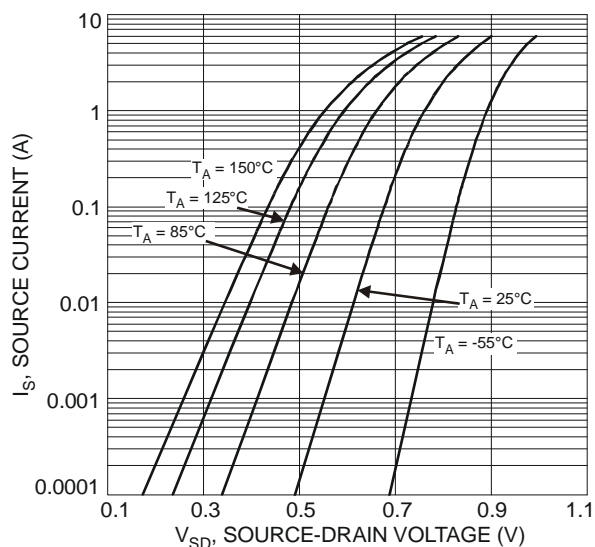
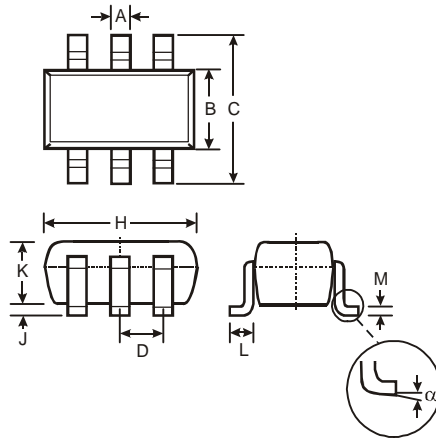

Fig. 8 Diode Forward Voltage vs. Current

Package Outline Dimensions



SOT-26			
Dim	Min	Max	Typ
A	0.35	0.50	0.38
B	1.50	1.70	1.60
C	2.70	3.00	2.80
D	—	—	0.95
H	2.90	3.10	3.00
J	0.013	0.10	0.05
K	1.00	1.30	1.10
L	0.35	0.55	0.40
M	0.10	0.20	0.15
α	0°	8°	—
All Dimensions in mm			

Suggested Pad Layout

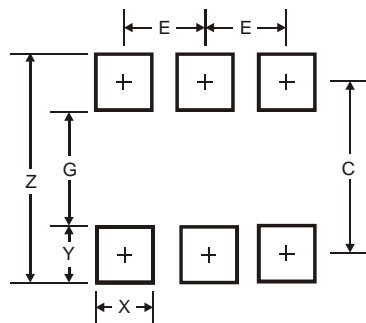

Dimensions	Value (in mm)
Z	3.20
G	1.60
X	0.55
Y	0.80
C	2.40
E	0.95